

## A multi objective optimization of transmission expansion planning using genetic algorithm considering reliability criteria

Srinivasulu G\*, Subramanyam B\*\* and Surya Kalavathi M\*\*\*

*An electric power system plays a crucial role in the economic and social development of a country. Economic growth in India has spurred the need for more power and hence the infrastructure to transport the power. Sufficient transmission capacity is very essential in any long-term planning for improving the availability and supply of power. So Transmission Expansion Planning (TEP) is integral to the development of a stable and reliable power infrastructure. TEP in future is a very complex task which needs a coordinated and analytical analysis of various scenarios and contingencies. In this work we have implemented a scheme for TEP which factors load growth and considers N-1 contingency. Both economics and technical considerations are considered in the appraisal of the most desirable transmission network. A multi objective optimization approach is suggested and the optimization of the expansion plan is done with the help of Backward Search (BS), Forward Search (FS), Hybrid Search (HS) and Genetic Algorithm (GA). The TEP is prepared for a 6 Bus-Roy Billinton Test System (RBTS). Transmission Planning Index (TPI) is introduced to provide a clear indication to the planner about the choice of the plan. The plans suggested by different optimization algorithms are compared in terms of performance measures and reliability indices.*

**Keywords:** *Transmission Expansion Planning (TEP), Backward search (BS), Forward Search (FS), Hybrid Search (HS), Genetic Algorithm (GA), N-1 Contingency, Reliability indices and Roy Billinton Test system (RBTS).*

### 1.0 INTRODUCTION

India's GDP has grown by 6.3% [1] in 2011-12 and 5% in 2012-13 with the rise in industrial and commercial activity in the country. Disposable income has risen by 19.1% and population has increased by 15 million [1] in this period. With the growth in economy, energy demand has also seen a ~7% y-o-y growth [2]. Despite having installed power generation capacity of 225 GW [2] and power demand of 135 GW [2] (as of May 2013), India faced a peak power deficit of 9% (12 GW). One of the major reasons for this situation is the inadequate transmission capacity,

not matching the generation capacities and load requirements [2]. Based on the current supply position, Resource rich states like Chhattisgarh are also unable to evacuate the excess power [2]. With an expected power generation capacity in excess of 30,000 MW by end of 12<sup>th</sup> plan, against the state's peak demand requirement of about 3,300 MW, currently there is only 7000 MW of transmission capacity available to evacuate power from the state [2]. With the installed power generation capacity planned to increase to 388 GW by 2022, transmission sector will need to do quite a lot of catching [2].

\*Associate Professor, Department of EEE, NEC, Nellore - AP, 524004. Email: gs\_meghana@rediffmail.com.

\*\*Professor, Department of EEE, PBRVITS, Kavali - AP, 524201. Email: bsubramanyamb@gmail.com.

\*\*\*Professor, Department of EEE, JNTUH, Hyderabad - TS, 500085. Email: munagala12@gmail.com.

Adequate transmission capacity is very essential in any long-term planning for improving the availability and supply of power. So Transmission Expansion Planning is integral to the development of a stable and reliable power infrastructure. Planning for transmission lines in to the future is a very complex task which needs a coordinated and analytical analysis of various scenarios and contingencies. So the optimal design of transmission system expansion is an important part of the overall planning task of electric power system. The transmission expansion planning (TEP) problem of electrical power systems consists in finding the transmission lines and / or transformers that should be constructed so that the system can operate in an adequate way and in a specified planning horizon. Transmission Expansion planning should reduce investment cost and operational cost as well as to meet various constraints during normal and contingency conditions i.e. Investment cost involves the cost of adding new transmission elements and the operational cost would be the cost of power losses during the element life. Transmission Expansion Planning must not violate the basic constraint i.e. the limiting transfer capacity of a Transmission line. The contingency is, in fact, an outage taking place on a single element such as a line, a transformer, and / or a generator or some other elements. The N-1 condition is referred to as outage single element, therefore, the Transmission Expansion Planning should be done that system must meet the load and no violation happens. The objective of the ensemble planning, transmission programming, heuristic of transmission network planning functions is to determine the installation plans of new facilities (lines and other network equipment) so that the resulting bulk power system may be able to meet the forecasted demand at the lowest cost, while satisfying prescribed technical, financial, and reliability criteria. Reliability and risk assessment for the development of a reliable, economically efficient power system expansion and operation plan is an invaluable process.

This paper is aimed at developing a flexible decision method to select a favorable plan among various transmission system expansion

alternatives, based on economic and technical criteria, and system constraints studies under normal and contingency conditions. In this proposed work we classify the transmission planning into two dimensions like economic and technical criteria. Transmission Planning Index (TPI) is derived and it can be used as an important criterion for decision making and transmission planning in the planning horizon. Starting from a reference plan, alternative expansion plans are derived based on postponement / anticipation of circuit implementations. These plans are then ranked by using the TPI index is obtained. This study aims at a method for decision making that allows selecting a favorable plan among multiple options for power transmission system expansion with a limited amount of investment. In this work we have implemented a scheme for Transmission Expansion Planning (TEP) which factors load growth and considers N-1 contingency. The optimization of the expansion plan is done with the help of Back Ward Search (BS), Forward Search (FS), Hybrid Search (HS) and Genetic Algorithm (GA). The expansion plan is suggested for a 6 Bus-Roy Billinton Test System (RBTS). The plans suggested by different optimization algorithms are compared in terms of number of new lines, length of new lines and the total cost of expansion.

## 2.0 LITERATURE REVIEW

The Transmission Expansion Planning is posed like an optimization problem with an objective function, subject to set of constraints. These constraints try to model great part of the technical, economic and reliability criteria imposed to the transmission expansion. Several methods have been proposed to obtain the optimum solution for the transmission expansion problem. Mostly using classical optimization techniques like linear programming [3], dynamic programming [5], nonlinear programming [6] and mixed integer programming [7]-[10]. Optimization technique like Benders [11]-[14] and hierarchical decomposition [15] have been also used, as well as the combination of the decomposition technique with other approaches, solving the problem with Branch and Bound algorithm [17]. Obtaining a

optimal solution is the primary problem when mathematical optimisation techniques are employed to solve the transmission expansion problem. The computation time is also high when discrete variables are used for modelling the investments and stochastic modelling is used for planning under uncertainty.

The heuristic methods are the current alternative to the mathematical optimization models. The term heuristic is used to describe all those techniques that, instead of using a classical optimization approach, go step-by-step generating, evaluating and selecting expansion options. The heuristic process is carried out until the plan generation algorithm is not able to find a better plan considering the assessment criteria that were settled down.

One of the first heuristic approaches that tried to solve the transmission expansion problem was proposed by Fischl et al. [16]. A common heuristic procedure is to allocate the additional circuits using a sensitivity analysis [18]-[20]. Some of these models deal with purely electric sensitivities, see Bennon et al. [22], with procedures to remove overloads. Other, use the sensitivity with respect to the load curtailment or other index of the system behavior, for example least effort criterion used by Monticelli et al. [20], with respect to susceptance reinforcement, when the dc load flow is used, see Pereira et al. [21], and Dechamps et al. [23]. All of them start from an initial plan and after successive evaluations, they improve it until obtain a quasioptimal plan.

Procedures based on the flow through fictitious lines of unlimited capacity have also been proposed using lines from the “overload network” used by Villasana et al. [3], Garver [4], and Levi et al. [17]. The flow through this network is penalized using the “guide numbers”, to assure that mathematical model uses all the real circuit capacity first. These procedures combine heuristic rules with mathematical optimization algorithms to solve the problem. They go forming step-by-step the transmission expansion planning, installing a single new circuit at a time. This new circuit is added in the corridor with the largest

flow through the corresponding corridor of the overload network.

Lattorre et al. [24] proposed a heuristic method that took advantage of the natural decomposition of the transmission expansion problem in operation and investment problems. The use of heuristic algorithms is very attractive because good feasible solutions can be found, that is, very competitive economically, with small computational effort. However, they can not guarantee in an absolute way, mathematically speaking, the optimal transmission expansion.

### 3.0 PROBLEM DEFINITION

The deregulation of power system has introduced new challenges in the field of Transmission Expansion Planning. The main goal of deregulation can be summarized as defining a competitive market for maximizing the overall social welfare while maintaining the power system reliability. Any new model for Transmission Expansion Planning should be capable of considering the objectives and interests of each stakeholder and also should be based on cost-benefit analysis instead of classical least cost approach. Moreover, the deregulation process has resulted in increased uncertainties mainly regarding generation expansion planning.

Multi-objective optimization is a suitable tool for handling different incommensurable objectives with conflicting / supporting relations or not having any mathematical relation with each other. A good plan should take into account for all kinds of uncertainties that could happen in the future. The multi-objective optimization problem can be transformed into a scalar optimization problem by weighted sum approach, where technical criteria will be evaluated together with the investment cost associated with each scheme to provide a Transmission Planning Index. The objective function is given below.

$$\begin{aligned} \text{Min } \{TPI = & W_C \times C_I + W_P \times PI + W_R \\ & \times LI + W_F \times EENS + W_D \\ & \times EDNS + W_L \\ & \times PLC\} \end{aligned} \quad \dots(1)$$

Where  $W_C, W_P, W_R, W_F, W_D$  and  $W_L$  are weighting factors for cost, voltage profile, line loading, and Expected Energy Not Supplied, Expected Demand Not Supplied and Probability of Load Curtailment Indices .

$W_C + W_P + W_R + W_F + W_D + W_L = 1$  is included to accommodate the planners preferences and significance that has to been given for each criteria as per his need and requirement. The plan that has the minimum target value will be chosen as the final expansion plan.

### 3.1 Economic Criteria

The economics of alternate facilities play a major role in the decision making process for transmission system expansion planning, therefore, should be consider for transmission planning.

### 3.2 Cost

The economic considerations can be consisting of *investment, maintenance and operational cost*.

$$C_x = \sum_{x=1}^T (I_{xt} + M_{xt} + O_{xt}) \quad \dots(2)$$

Where,

$C_x$  : The total cost of plan  $x$

$I_{xt}$  : Total investment cost.

$M_{xt}$  : Maintenance cost of plan  $x$

$T$  : Operational cost

$T$  : the horizontal years of planning

### 3.3 Technical Criteria

Technical criteria are another of major considerations in system operation and planning. Permissible operating ranges of voltage and lines loading are the essential constraints in power networks operation and design, one of the essential tasks power network designers maintain these constraints at a level appropriate to the electric power systems in different conditions. Here, we classify the technical criterion into three

aspects including Voltage Profile Index (**PI**), Line Loading Index (**LI**), and Expected Energy Not Supplied (**EENS**) Index. Similarly the adequacy of the proposed expansion plan is analyzed with help of adequacy indices namely Expected Demand Not Supplied (**EDNS**) and Probability of Load Curtailment (**PLC**).

### 3.4 Voltage Profile Index (PI) [29]

One of the primary reasons for numerous blackouts across the globe has been inadequate voltage planning. Considering the influence of voltage quality on the customer's equipment performance and also the increase on efficiency and lifetime of network equipment, the magnitude and status of voltage in power networks is one of the important parameters. The limits of the acceptable voltage levels are determined according to the exigencies of a secure operation of the available system electrical equipment. In this paper, the PI for the overall system is defined as

$$PI^L = \sum_{i \in N_{Low}} |V_i - 0.95| \quad \dots(3)$$

$$PI^H = \sum_{i \in N_{High}} |V_i - 1.05| \quad \dots(4)$$

$$PI = PI^L + PI^H \quad \dots(5)$$

Where,

$PI$  : voltage profile index

$PI^L$  : Voltage profile index when bus voltage falls below 0.95

$PI^H$  : Voltage profile index when bus voltage rises above 1.05

$V_i$  : The voltage magnitude of  $i^{th}$  bus

$N_{Low}$  : A set of bus with allowable voltage at each bus, typically 0.95 Pu

$N_{High}$  : A set of bus with allowable voltage at each bus, typically 1.05 Pu

### 3.5 Line Loading Index (LI) [29]

For desirable operation of power system should guarantee that current flow into the all network facilities are in permissible ranges. In this section, with attention to the lines loading status in power networks, a criterion is brought for the overall assessment of system's lines loading status. The limits of the acceptable current levels are determined according to the exigencies of a secure operation of the available system electrical equipment. The *LI* for the overall system is defined as

$$LI = \sum_{j \in SB} \frac{I_j}{I_{j \max}} \quad \dots(6)$$

Where,

LI : Line loading index

$I_j$  : The current magnitude of  $j^{th}$  branch

$I_{j \max}$  : The maximum current magnitude of branch

SB : Set of branches with current over 80%

### 3.6 Expected Energy Not Supplied (EENS) Index [29]

EENS is the expectation of the energy loss caused to customers by insufficient power supply. The EENS index for the overall system is defined as:

$$EENS = \sum_i \sum_k L_{ik} F_{fk} D_{ik} \quad \dots(7)$$

Where,

$L_{ik}$  : The load curtailment at bus i or the load not supplied at an isolated bus i

$F_{ik}$  : The frequency of occurrence of outage k at bus i

$D_{ik}$  : The duration in hours of the load curtailment

### 3.7 Expected Demand Not Supplied (EDNS) [29]

The expected demand not supplied is the expected value of load shedding caused by insufficient generating capacity of system or constraint of power grid in a given time defined as

$$EDNS = \sum_{l=1}^{Nl} \frac{C_l D_l}{TD} \quad \dots(8)$$

Where,

$C_l$  (MW) : System load curtailment

$D_l$  (hr) : Duration for system state

$N_l$  : Number of load curtailment system states

TD(hr) : Sum of the durations of all system states in a long system state transition sequence

### 3.8 Probability of Load Curtailment (PLC) [29]

The probability of load Curtailment is given by the index

$$PLC = \sum_{l=1}^{Nl} \frac{D_l}{TD} \quad \dots(9)$$

Where,

$D_l$ (hr) : Duration for system state l

$N_l$  : Number of load curtailment system states

TD(hr) : Sum of the durations of all system states in a long system state transition sequence

## 4.0 OPTIMIZATION TECHNIQUES

The TEP problem can be solved by available optimization techniques like backward search (BS) technique, Forward search (FS) technique, Hybrid search (HS) technique and Genetic Algorithms (GA). If the system is small, the search space can be completely checked to find



the best solution. Different types of topologies may be checked to find out the solutions which are feasible in addition to acceptable normal and N-1 condition. The candidates are added one-by-one in Forward search technique, but backward search technique works vice versa in such a way that, all candidates are initially added to the network and the candidates are removed one-by-one [25].

HS Technique is Backward-Forward-Decrease Method. The search space is enormous for large scale systems, if backward approach is tried for both normal and contingency conditions. One of the possible methods to overcome the difficulties, initially BS technique is applied for the network for normal conditions (no contingency). The solution speed will be high and acceptable due to no contingency is considered at this stage. Thereafter, the forward approach is employed to find the solution in the presence of all foreseen contingencies (N - 1) and then decrease is method is applied to find optimal solution [25]. Obviously, for a large scale system, the number of candidates would be high and the solution normally ends up with limited number of choices. Moreover, although the optimality of the solution cannot be guaranteed, the solution speed and accuracy would be quite acceptable.

The main idea of GA is to mimic the natural selection and the survival of the fittest [26]. In GA, the solutions are represented as chromosomes. The chromosomes are evaluated for fitness values and they are ranked from best to worst based on fitness value. The process to produce new solutions in GA is mimicking the natural selection of living organisms, and this process is accomplished through repeated applications of three genetic operators: selection, crossover, and mutation. First, the better chromosomes are selected to become parents to produce new offspring (new chromosomes) [26]. To simulate the survivor of the fittest, the chromosomes with better fitness are selected with higher. The selection probabilities are usually defined using the relative ranking of the fitness values. Once the parent chromosomes are selected, the crossover operator combines the chromosomes of the

parents to produce new offspring (perturbation of old solutions). Mutation is a mechanism to inject diversity into the population to avoid stagnation. In addition to the population size and the maximum number of iterations, several decisions on parameters must be made for GA. Crossover method and crossover probability are the second set of decisions to be made. Finally, the mutation method and mutation probability must be selected as they may help to maintain the diversity of the population by injecting new elements into the chromosomes. In general, these three sets of decisions are set empirically using pilot runs. The flow chart of the Genetic Algorithm is shown in Figure 1.

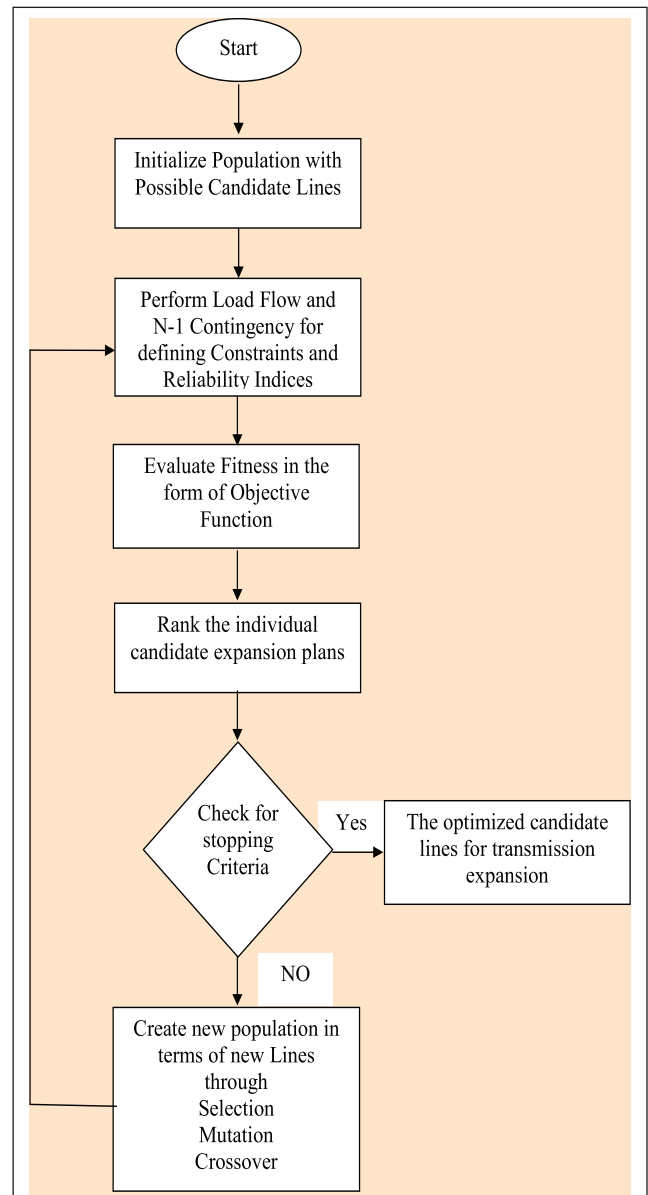

FIG. 1 FLOW CHART FOR TEP USING GENETIC ALGORITHM

## 5.0 RESULTS AND DISCUSSION

The proposed approach is coded using Matlab Version 7.1 and MatPower version 5 [28] is used to run the optimal power flow solver using Newton - Raphson method. The simulations are carried out in a system having Core 2 Duo processor clocking at a speed of 2 GHz with a RAM of 2GB.

A Roy Billinton Test System (RBTS) is used for the proposed work. The details of the system can be accessed from [27] and the line diagram of the system is given in the Figure II. The system has 2 generator (PV) buses, 4 load (PQ) buses, 9 transmission lines and 11 generating units. The minimum and the maximum ratings of the generating units are 5 MW and 40 MW respectively. The voltage level of the transmission system is 230 kV and the voltage limits for the system buses are assumed to be 1.05 p.u. and 0.97 p.u. The system peak load is 185 MW and the total installed generating capacity is 240 MW. The transmission system contains single lines and lines on a common right of way and/or on a common tower. The results of the transmission expansion planning as optimized by different methods are given in Table I. In this paper, load growth of 50% and 75% was considered for Transmission Expansion Planning.

### Case 1: Load growth of 50%

Table 1, Table 2, Table 3 and Table 4 explains number of new lines added, over loading of lines, reliability indices and TPI for load growth of 50% respectively. Detailed analysis of results is explained below.

It can be observed from Table 1 that, 6 numbers of new lines are added for through optimization achieved using BS, FS and HS methods to a total length of 875 Ckm and at a cost of 210000 \$ for the newly added lines. Optimization using Genetic Algorithm resulted in the addition of 6 new lines for a distance of 675 Ckm at an additional cost of 162000 \$. The Figure 3 illustrates the TEP as obtained using Genetic Algorithm. The dotted

lines indicate new transmission lines added as per the specific optimization algorithm.

In this paper, N-1 contingency of single line outage is considered. AC Load Flow was done by removing lines and the total overload is observed. There was no overloading of any transmission line for the expansion suggested by all four methods.

The Table 3 details about various factors for different network expansion as suggested by different algorithm. The table gives the details related to any single line outage. To analyze the reliability indices Monte Carlo simulation is employed with 50,000 numbers of samples and a minimum of 50 simulation runs. From the Table 3, it can be observed that the expansion plan suggested by GA optimisation performs better in terms of reliability indices EENS, EDNS and PLC. In order to give the planner a choice in emphasizing the importance of every factor as per his need, a Transmission Planning Index (TPI) is suggested as equation (1). TPI indicates that economic, technical, performance and reliability index for Transmission Expansion Planning and less value of TPI indicates the best plan.

Where  $W_C$ ,  $W_P$ ,  $W_R$ ,  $W_F$ ,  $W_D$ ,  $W_L$  are weighting factors for cost, voltage profile, line loading, and Expected Energy Not Supplied, Expected Demand Not Supplied and Probability of Load Curtailment Indices.

$W_C + W_P + W_R + W_F + W_D + W_L = 1$  is included to accommodate the planners preferences and significance that has to be given for each criteria as per his need and requirement. The plan that has the minimum target value will be chosen as the final expansion plan. In this work the  $W_C$  is chosen as 0.30 with the remaining parameters assigned a value of 0.14. The TPI as arrived at using different methods of optimization is listed in Table 4 below. For easy representation the index is scaled to 10. From Table 4, it can be concluded that GA gives best plan for load growth of 50%.

**Case 2: Load growth of 75%**

Table 5, Table 6, Table 7 and Table 8 explains number of new lines added, over loading of lines, reliability indices and TPI for load growth of 75% respectively. Detailed analysis of results is explained below.

It can be observed from Table 5 that, 7 numbers of new lines are added through optimization achieved using BS and HS methods to a total length of 950 Ckm and at a cost of 228000 \$ for the newly added lines. 8 numbers of new lines are added through optimization achieved using FS method to a total length of 1000 Ckm and at a cost of 240000 \$ for the newly added lines. Optimization using Genetic Algorithm resulted in the addition of 8 new lines for a distance of 800CKm at an additional cost of 192000 \$. The Figure 4 illustrates the TEP as obtained using Genetic Algorithm. The dotted lines indicate new transmission lines added as per the specific optimization algorithm.

In this paper, N-1 contingency of single line outage is considered. AC Load Flow was done by removing lines and the total overload is observed. In the expansion suggested by Backward Search outage of line 1-3 results in maximum overload of single line totaling to 0.5586 p.u. The average number of lines that are overloaded because of any given single line outage is 1 for the expansion plan suggested by Backward search. Similar results are observed in the case of Hybrid Search also, as both Backward Search and Hybrid Search resulted in same expansion plan.

In the network expansion suggested by Forward search outage of line 1-3 results in maximum overload of single line totaling to 0.60670 p.u. The average number of lines that are overloaded because of any given single line outage is 1 for the expansion plan suggested by Forward search. Transmission line expansion as suggested by Genetic Algorithm has provided results that better when compared to BS, FS and HS methods used in this paper. The network expansion suggested by Genetic Algorithm the outage of line 1-3 results in maximum overload of single line totaling to 0.5373 p.u. Except for line 1-3 other line outages did not produce overload of the system.

The Table 7 details about various factors for different network expansion as suggested by different algorithm. The table gives the details related to any single line outage. To analyze the reliability indices Montecarlo simulation is employed with 50,000 numbers of samples and a minimum of 50 simulation runs. From the Table 7, it can be observed that the expansion plan suggested by GA optimisation performs better in terms of reliability indices EENS, EDNS and PLC.

The TPI as arrived at using different methods of optimization is listed in Table 8 below. For easy representation the index is scaled to 10. From Table 8, it can be concluded that GA gives best plan for load growth of 75%.

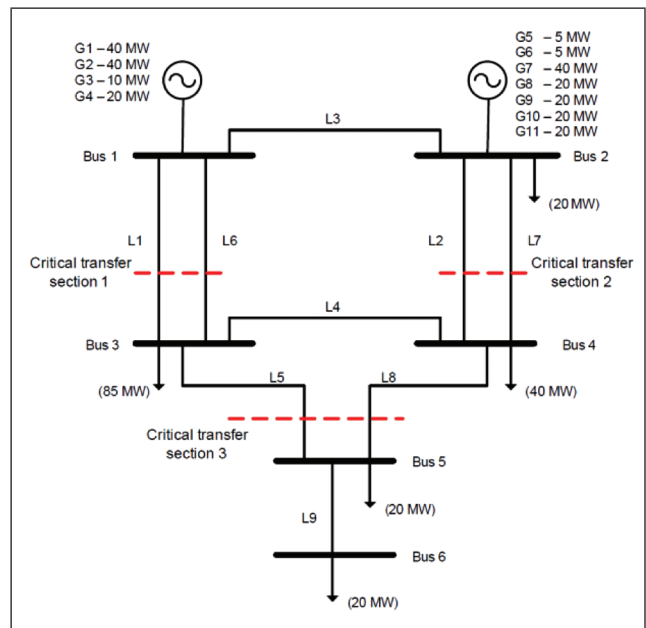

FIG. 2 SINGLE LINE DIAGRAM OF 6-BUS RDTS

TABLE 1 NEW LINES ADDED AFTER TEP USING DIFFERENT METHODS FOR LOAD GROWTH OF 50%			
BS	FS	HS	GA
1-3	1-3	1-3	1-3
2-4	2-4	2-4	1-2
1-2	1-2	1-2	2-4
2-4	2-4	2-4	4-5
4-5	4-5	4-5	4-5
5-6	5-6	5-6	5-6



TABLE 2					
OVERLOAD LINES DUE TO N-1 CONTINGENCY AFTER TEP FOR LOAD GROWTH OF 50%					
Sl. No	Item	BS	FS	HS	GA
1	Maximum number of lines overloaded	0	0	0	0
2	Line Outage which causes the Maximum Overload	0	0	0	0
3	Maximum over Load (p.u.)	0	0	0	0
4	Average total overload for anygiven line outage (p.u)	0	0	0	0

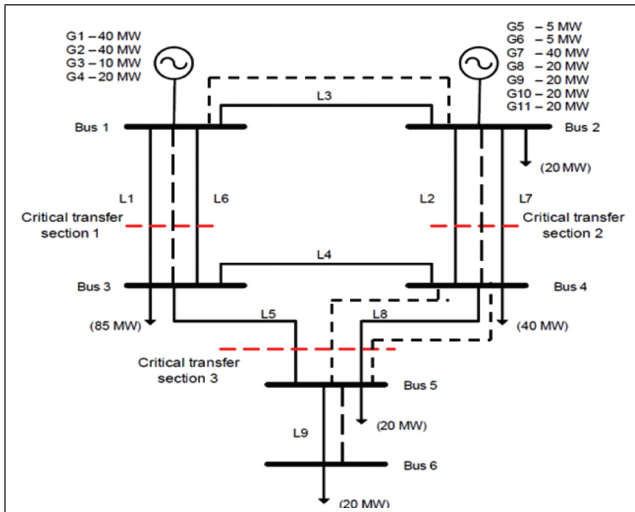

FIG. 3 TEP OBTAINED USING GENETIC ALGORITHM FOR LOAD GROWTH OF 50%

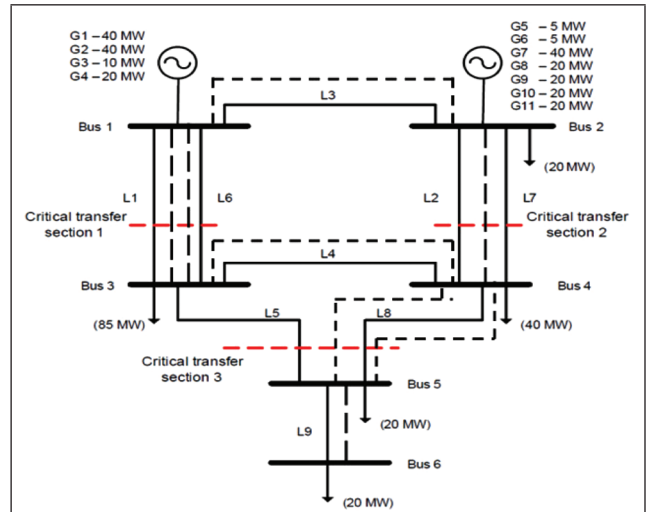

FIG. 4 TEP OBTAINED USING GENETIC ALGORITHM FOR LOAD GROWTH OF 75%

TABLE 3					
TEP USING DIFFERENT METHODS FOR LOAD GROWTH OF 50% *					
ITEM	BEFORE PLANNING	BS	FS	HS	GA
EENS	1040.23	788.40	788.40	788.40	744.46
EENS MAX	1496.53	2190.00	2190.00	2190.00	2146.20
EENS MIN	571.84	219.00	219.00	219.00	219.00
EDNS	0.11	0.09	0.09	0.09	0.09
PLC	0.00	0.00	0.00	0.00	0.00
V Profile Index	0.00	0.00	0.00	0.00	0.00
L Load Index	0.05	0.04	0.04	0.04	0.04
Number of new lines added	NA	6	6	6	6
CKM of lines added	NA	875	875	875	675
Total cost of new lines	NA	210000	210000	210000	162000

\* All units are in MW

TABLE 4					
TPI USING DIFFERENT METHODS FOR TEP FOR LOAD GROWTH OF 50%					
S.No	Item	BS	FS	HS	GA
1	Transmission Planning Index	6.31	6.31	6.31	4.87

TABLE 5			
NEW LINES ADDED AFTER TEP USING DIFFERENT METHODS FOR LOAD GROWTH OF 75%			
BS	FS	HS	GA
1-3	1-3	1-3	1-3
2-4	2-4	2-4	1-2
1-2	1-2	1-2	3-4
1-3	3-5	1-3	1-3
2-4	1-3	2-4	2-4
4-5	2-4	4-5	4-5
5-6	4-5	5-6	4-5
-	5-6	-	5-6

TABLE 6					
OVERLOAD LINES DUE TO N-1 CONTINGENCY AFTER TEP FOR LOAD GROWTH OF 75%					
S.No	Item	BS	FS	HS	GA
1	Maximum number of lines overloaded	1	1	1	1
2	Line Outage which causes the Maximum Overload	1-3	1-3	1-3	1-3
3	Maximum over Load (p.u.)	0.55	0.60	0.55	0.53
4	Average total overload for anygiven line outage (p.u)	0.55	0.16	0.55	0.14

TABLE 7					
TEP USING DIFFERENT METHODS FOR LOAD GROWTH OF 75% *					
ITEM	BEFORE PLANNING	BS	FS	HS	GA
EENS	1040.23	826.06	765.62	826.06	745.24
EENS MAX	1496.53	1839.60	1489.20	1839.60	2671.80
EENS MIN	571.84	43.80	219.00	43.80	43.80
EDNS	0.11	0.09	0.08	0.09	0.08
PLC	0.00	0.00	0.00	0.00	0.00
V Profile Index	0.00	0.00	0.00	0.00	0.00
L Load Index	0.05	0.05	0.04	0.05	0.04
Number of new lines added	NA	7	8	7	8
CKM of lines added	NA	950	1000	950	800
Total cost of new lines	NA	228000	240000	228000	192000

\* All units are in MW

TABLE 8					
TPI USING DIFFERENT METHODS FOR TEP FOR LOAD GROWTH OF 75%					
S. No	Item	BS	FS	HS	GA
1	Transmission Planning Index	6.85	7.21	6.85	5.77

## 6.0 CONCLUSION

Transmission Expansion Planning (TEP) is made for load growth of 50% and 75% hike to normal load using Backward Search (BS), Forward Search (FS), Hybrid Search (HS) and Genetic Algorithm (GA) for 6-bus RBTS. It can be observed that the network expansion as suggested by the GA optimization performs much better in term of N-1 contingency analysis and also comparable in terms of cost of the expansion as suggested by other methods. The time taken for optimization for all the four methods is comparable. It can be observed that the Transmission Expansion Plan obtained by GA optimisation performs better in terms of reliability indices EENS, EDNS and PLC. The Transmission planning index as arrived at using different methods of optimization is less for GA optimization method for Transmission Expansion Planning. Therefore TEP suggested by GA is best plan compared with other methods.

## 7.0 REFERENCES

- [1] <http://data.worldbank.org/country/india>
- [2] [http://www.ficci.com/spdocument/20311/power-transmission-report\\_270913.pdf](http://www.ficci.com/spdocument/20311/power-transmission-report_270913.pdf)
- [3] R Villasana, L L Garver and S L Salon, "Transmission network planning using linear programming", IEEE Trans. Power Appar. Syst., Vol PAS-104, pp 349-356, Feb. 1985.
- [4] L L Garver, "Transmission network estimation using linear programming", IEEE Trans. Power Appar. Syst., Vol PAS-89, pp 1688-1697, Sep./Oct. 1970.
- [5] Y P Dusonchet and A.H.El-Abaid, "Transmission planning using discrete dynamic optimization", IEEE Trans. Power Appar. Syst., Vol PAS-92, pp 1358-1371, July 1973.
- [6] H K Yousef and R Hackam, "New Transmission planning model", IEEE Trans. Power Syst., Vol. 4, pp 9-18, Feb 1989.
- [7] L Bahiense, G C Oliveira, M Prereira and S Granville, "A mixed integer conjunctive model for transmission network expansion", IEEE Trans. Power Syst., Vol. 16, pp 560-565, Aug., 2001.
- [8] S Haffiner, A Monticelli, A Gurcia, J Mantovani and R Romero, "Branch and bound algorithm for transmission expansion planning using a transportation model", Proc. Inst. Elect. Eng. – Gen. Transm. Dist., Vol. 147, pp. 149-156, May 2000.
- [9] A Seifu, S Salon and G List, "Optimization of transmission line planning including security constraints", IEEE Trans. Power Syst., Vol. 4, pp 1507-1513, Oct. 1989.
- [10] A Santos, P M Franca and A Said, "An optimization model for long range transmission expansion planning", IEEE Trans. Power Syst., Vol. 4, pp 94-101, Feb 1989.
- [11] S Binato, M V F Pereira and S Granville, "A new Benders decomposition approach to solve power transmission network design problems", IEEE Trans. Power Syst., Vol. 16, pp 235-240, May, 2001.
- [12] P T Samasphyrpu, A Renaud and P Carpentier, "Transmission network planning: An efficient Benders decomposition scheme", in Proc. 13<sup>th</sup> PSCC in Trondheim, pp. 487-494, 1999.
- [13] G C Oliveria, A P C Costa and S Binato, "Large scale transmission network planning using optimization and heuristic techniques", IEEE Trans. Power Syst., Vol. 10, pp 1828-1834, Nov., 1995.
- [14] S N Siddiqi and M L Baughman, "Valid based transmission planning and the effects of network models", IEEE Trans. Power Syst., Vol. 10, pp 1835-1842, Nov., 1995.
- [15] R Romero and A Monticelli, "A hierarchical decomposition approach for transmission network expansion planning", IEEE Trans. Power Syst., Vol. 9, pp 373-380, Feb., 1994.
- [16] R Fischl and W R Puntel, "Computer aided design of electric power transmission network", in Proc. IEEE winter power meeting, 1972.

- [17] V A Levi and M S Calovic, "A new decomposition based method for optimal expansion planning of large transmission networks", IEEE Trans. Power Syst., Vol. 6, pp 937-943, Aug., 1991.
- [18] A O Ekwue and B J Cory, "Transmission system expansion planning by interactive methods", IEEE Trans. Power Appar. Syst., Vol. PAS-103, pp 1583-1591, July 1984.
- [19] A O Ekwue, "Investigations of the transmission systems expansion problem", Electrical and Energy systems, Vol. 6, pp. 139-142, July 1984.
- [20] A Montocelli, A Santos Jr, M V F Pereira, S H F Cunha, B J Parker and J C G Praca, "Interactive transmission network expansion planning using a least-effort criterion", IEEE Trans. Power Appar. Syst., Vol PAS-101, pp 3919-3925, Oct. 1982.
- [21] M V Pereria and L M V G Pinto, "Application of sensitivity analysis of load supplying capability to interactive transmission planning", IEEE Trans. Power Appar. Syst., Vol. PAS-104, pp 381-389, Feb. 1985.
- [22] R J Bennon, J A Juves, and A P Meliopoulos, "Use of sensitivity analysis in automated transmission planning", IEEE Trans. Power Appar. Syst., Vol. PAS-101, pp 53-59, Jan 1982.
- [23] C Dechamps and E Jamouille, "Interactive computer program for planning and expansion of meshed transmission networks", Int. J. Electr. Power Energy Syst., Vol. 2, pp. 103-108, Apr. 1980.
- [24] G Latorre-Bayona and I J Perez-Arriaga, "Chopin, a heuristic model for long term transmission expansion planning", IEEE Trans. Power Syst., Vol. 9, pp 1886-1894, Nov., 1994.
- [25] Hossein Siefi and Mohammad Sadegh Sepasian, "Electric Power System Planning", Springer-Verlag Berlin Heidelberg 2011.
- [26] G Srinivasulu and Dr B Subramanyam, "A comprehensive Transmission Expansion Planning Strategy for Developing Countries", IJERD, Vol. 2, Issue 11, August 2012, PP 7-13.
- [27] R Billinton, S Kumar, N Chowdhury, K Chu, K Debnath, L Goel, E Khan, P Kos, G Nourbakhsh, J Oteng-Adjei "A Reliability Test System For Educational Purposes - Basic Data", IEEE Transactions on Power Systems, Vol. 4, No. 3, August 1989.
- [28] <http://www.pserc.cornell.edu/matpower>