

## Measurement and Control of Electrical Energy for the Efficient Energy Management

Manish Kumar Ghodki\*

*“Measurement and Control of Electrical Energy for the Efficient Energy Management” is based on smart energy metering which has its own distribution, controlling and monitoring system for the amount of electrical energy (KWh). It is also equipped with the control of alternative source of electricity (solar energy). This hardware project measures the electrical energy (kWh) as well as controls the amount of electrical energy from supply to load during day and night automatically. The measurement can be performed up to ten lac (10,00,000) units and controlling can be upto two lac (2,00,000) units with a unit range selection of 0–20 units and 20–2,00,000 units. In the controlling part, when the energy consumption from the main supply exceeds the preset limit, then the main supply will be automatically tripped and the project provides the alternative power supply in the absence of this mains supply by using the renewable (solar) energy source.*

### 1.0 INTRODUCTION

Electrical energy measurement and controlling are very important tasks in many applications. It is also important with a view to prevent the electrical energy crisis.

As very less work in electronic metering as one-chip solution is reported, therefore, this work gives directions in the energy metering devices as follows: one-chip solution for the energy metering device, low power consumption of the device itself, measurement and controlling of the energy consumption. Therefore, the project discussed here focuses on low power consumption with increased integration of components into a single System on Chip-based IC (SoC), thereby reducing the area. The low power and small area will enable low-cost meters in the near future, which is not possible with traditional approaches.

The system described here is designed to provide electrical energy for the purpose of measurement

and controlling and also provide power for lighting pathways at nights. Renewable energy on a small scale is still a relatively expensive option compared to “conventional energy” use. In the current situation, the use of renewable energy (except from large wind farms) to meet energy demand is not cost-effective compared to the use of conventional fuel-based energy, where this energy is supplied via a mains electricity supply network. However, renewable energy has environmental appeal even though this is less quantifiable in terms of the reduced pollution compared to conventional energy. Hence, it is hoped that projects such as this will foster enthusiasm and encourage the use of renewable energy.

### 2.0 DESIGN AND DEVELOPMENT OF HARDWARE

The block diagram of the hardware in its simplest form is shown in Figure 1.

\*Department of Energy, Maulana Azad National Institute of Technology (MANIT), Bhopal, M.P., India. E-mail: markmkg@gmail.com

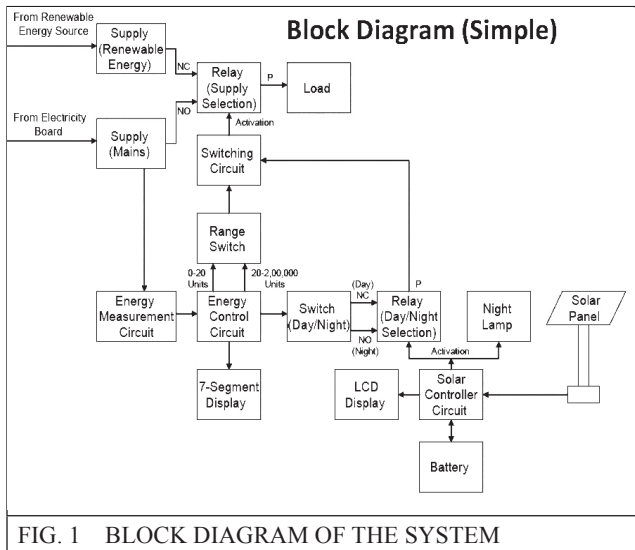

FIG. 1 BLOCK DIAGRAM OF THE SYSTEM

“Measurement and Control of Electrical Energy for the Efficient Energy Management” can be worked in two ways: either for electrical energy measurement or for electrical energy control.

For the electrical energy measurement, according to the block diagram (Figure 1), the supply from the electricity board (mains) is given to the energy measurement circuit. Here, the energy measurement has not been applied for the renewable energy supply, since the renewable energy supply is free in the environment. Now, the energy measurement circuit sends the pulses to the energy control circuit. This project works on 100 pulses per kWh, means that 100 pulses will be required to register 1 unit of electrical energy. On the basis of these pulses, the energy control circuit then processes on these pulses and converts it to the respective amount of electrical energy (kWh or units). This amount of electrical energy is then displayed on the 7-segment display.

For the electrical energy, this circuit measures and controls the amount of electrical energy in kWh or units during day and night automatically. When the energy consumption of the load from the mains supply exceeds the preset limit, then the mains supply will be automatically tripped and after tripping, this project can provide the power supply from any renewable energy source.

### 3.0 DESIGN AND DEVELOPMENT OF SUB-CIRCUITS

#### 3.1 Rectifier and Switching Circuit

Rectifier circuit is designed to provide the power supply to the system, whereas, the design of switching circuit is based on the block diagram which is shown in Figure 2(a) and the developed hardware on the basis of this design is shown in Figure 2(b).

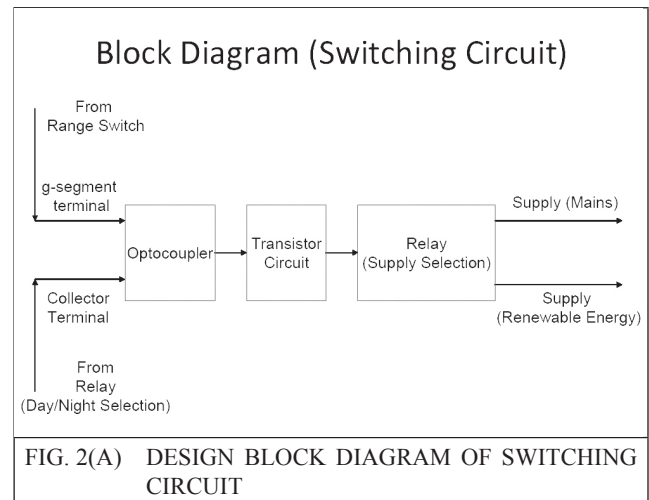

FIG. 2(A) DESIGN BLOCK DIAGRAM OF SWITCHING CIRCUIT

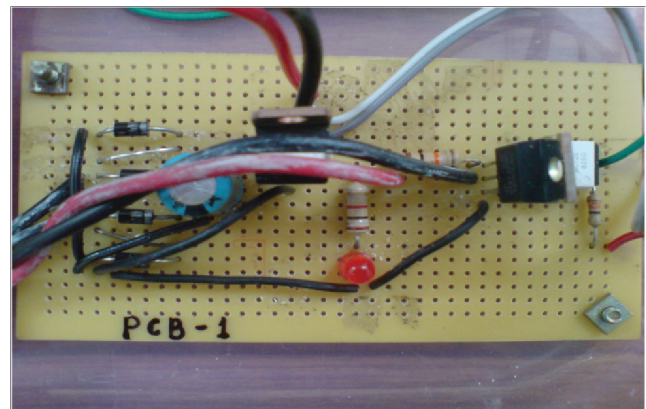

FIG. 2(B) DEVELOPMENT OF RECTIFIER AND SWITCHING CIRCUIT

Various parts of rectifier and switching circuit are as follows.

##### 3.1.1 Optocoupler

The input of optocoupler is LED, which glows with the help of two input signals. These two signals come from day-night selection relay and

g-segment from range switch. This LED then switches ON and OFF the transistor circuit.

### 3.1.2 Transistor Circuit

Transistor is also a part of optocoupler, one of the transistors is inside the optocoupler. Another transistor used to operate the relay is Power MOSFET IRF540N. Only the output of this transistor circuit is connected to the relay (supply selection). Power MOSFET has been chosen so that higher values of relay can also be connected for the higher amount of supply selection [7].

### 3.1.3 Relay (Supply Selection)

This relay decides whether mains supply or the supply from renewable energy has to be fed to the consumer load. This relay chooses only one supply at a time. The NC contact of this relay is connected to the renewable energy source so that freely available renewable energy can be fed to consumer all the time without switching on the project.

## 3.2 Energy Measurement Circuit

The design of this circuit is shown in the Figure 3(a). This designed circuit was further implemented on the PCB. This developed hardware has been shown in the Figure 3(b).

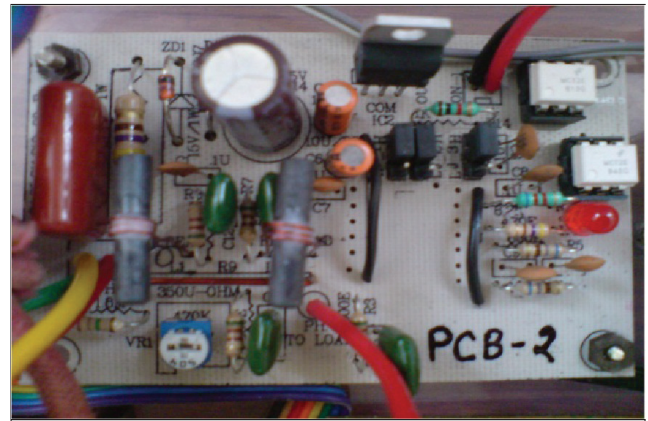
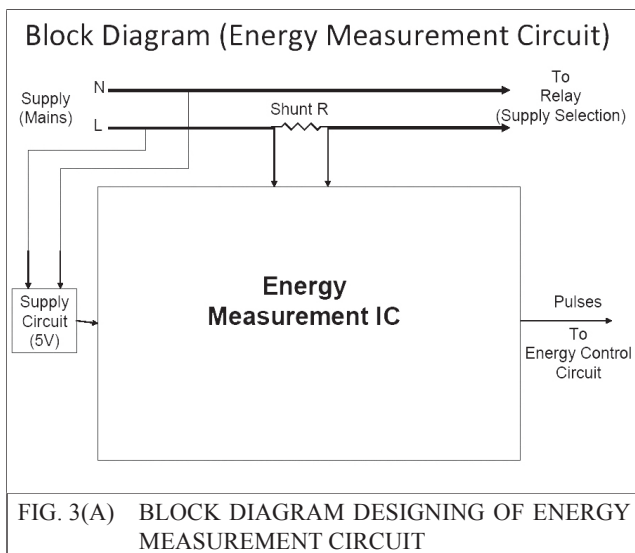

FIG. 3(B) DEVELOPMENT OF ENERGY MEASUREMENT CIRCUIT

Energy measurement circuit comprises of IC ADE7757 and some additional circuits for the working of this IC. It measures the electrical energy across the shunt resistance [6]. This circuit is for the measurement of mains electrical energy only and not for the measurement of renewable energy supply, since it is free in the environment. The important blocks shown in Figure 3(a) are as follows.

### 3.2.1 Supply Circuit

This supply circuit is used to provide 5V DC supply to the energy measurement circuit. This supply is provided with the help of half wave rectifier, zener diode for stepping down voltage and a linear regulator IC 7805.

### 3.2.2 IC ADE7757

The ADE7757 is an accurate electrical energy measurement integrated circuit. It is a pin reduction version of ADE7755 with an enhancement of a precise oscillator circuit that serves as a clock source to the chip. The ADE7757 eliminates the cost of an external crystal or resonator, thus reducing the overall cost of a meter built with this IC. The chip directly interfaces with shunt resistor. The ADE7757 provides instantaneous and average real power based on line current and voltage. The part specifications surpass the accuracy requirements as quoted in the IEC1036 standard. The only analog circuitry used in the ADE7757 is in the ADCs and reference circuit. All other signal processing (e.g., multiplication

and filtering) is carried out in the digital domain. This approach provides superior stability and accuracy over extremes in environmental conditions and over time. The small analog input full scale allows the chip to interface to low-value shunt resistances without losing dynamic range. The ADE7757 is available in 16-lead SOIC narrow-body package [5].

### 3.3 Energy Control Circuit

The design block diagram of this circuit is shown in Figure 4(a), which was further implemented on the PCB as shown in the Figure 4(b).

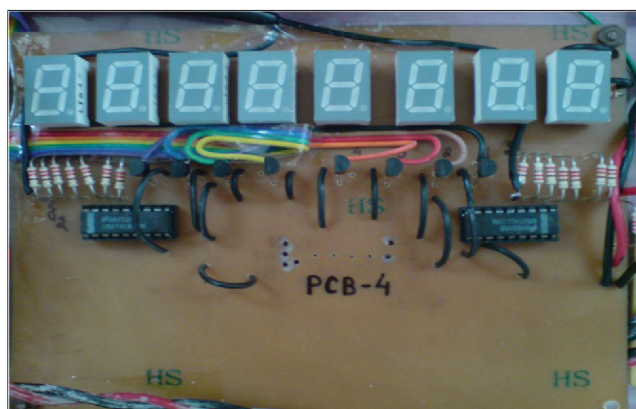
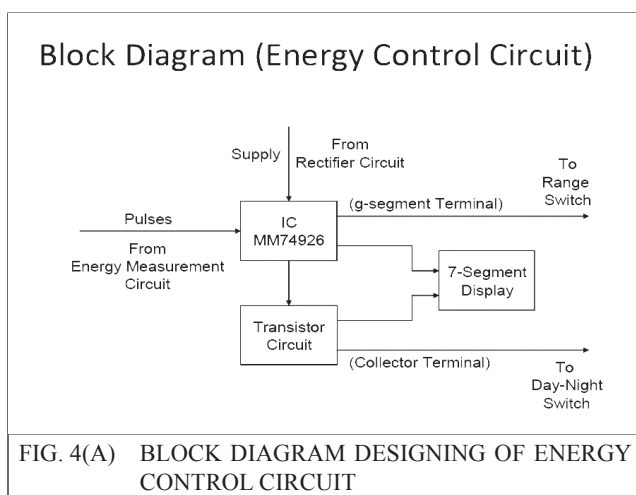

**FIG. 4(B) DEVELOPMENT OF ENERGY CONTROL CIRCUIT**

The energy control circuit uses two ICs MM74926 for sending the signal from g-segment from each IC to the two terminals of the range switch. Transistor circuit is used to send the signal from its collector terminals of 8-transistors to the day-night switch. Various blocks associated with

the energy control circuit shown in Figure 4 are as under.

#### 3.3.1 IC MM74926N

Two MM74926 ICs are cascaded to act as an 8-digit ripple counter. The MM74C926 CMOS counters consist of a 4-digit counter, an internal output latch, NPN output sourcing drivers for a 7-segment display, and an internal multiplexing circuitry with four multiplexing outputs. The multiplexing circuit has its own free running oscillator, and requires no external clock. The counters advance on negative edge of clock. A HIGH signal on the Reset input will reset the counter to zero, and reset the carry-out LOW. A LOW signal on the Latch Enable input will latch the number in the counters into the internal output latches. A HIGH signal on Display Select input will select the number in the counter to be displayed; a LOW level signal on the Display Select will select the number in the output latch to be displayed. The MM74C925 is a 4-decade counter and has Latch Enable, Clock and Reset inputs. The MM74C926 is like the MM74C925, except that it has a display select and a carry-out used for cascading counters. The carry-out signal goes HIGH at 6000, goes back LOW at 0000 [2].

#### 3.3.2 Transistor Circuit

The transistor circuit is nothing but a group of 8 transistors. The base of all these transistors is connected to the IC MM74C926N; collector terminals are connected to the eight 7-segment displays and all the emitter terminals are commonly connected to the ground. All the collector terminals are also connected to two 1-poles, 9-throw rotary switch, which are parallelly connected to each other. From this rotary switch, one collector terminal can be selected at a time for further controlling [8].

#### 3.3.3 7-Segment Display

This display is used to show the amount of electrical energy to be measured. It also displays



the amount of units up to which the electrical energy has to be controlled.

### 3.4 Solar Controller Circuit

The design block diagram of this circuit is shown in the Figure 5(a) which was further implemented on the PCB as shown in the Figure 5(b).

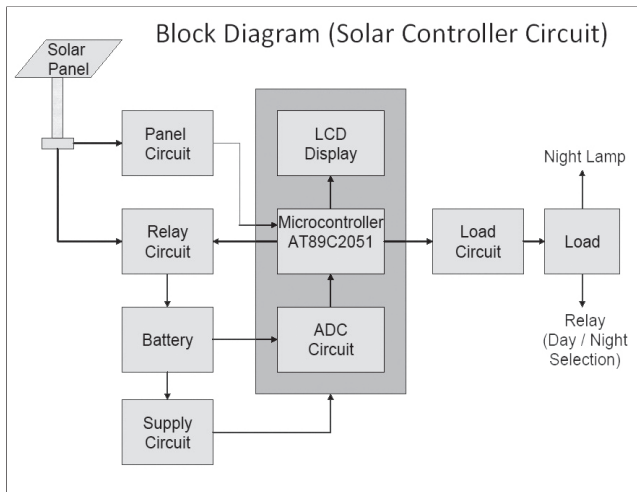

FIG. 5(A) BLOCK DIAGRAM DESIGNING OF SOLAR CONTROLLER CIRCUIT

In a block diagram shown in Figure 5(a), solar panel is used to give the DC output supply to the relay circuit. This relay is activated by the microcontroller according to the day and night condition. During the day condition, solar panel is connected to the battery, whereas during night, it is disconnected from the panel with the help of relay circuit. The battery voltage status is sent to the ADC circuit, which converts the battery’s variable analog voltage signal to the digital signal. This digital signal is then sent to the microcontroller, which is then used to display the status of the battery voltage on the LCD display. The charged battery is used to give the supply for the working of ADC circuit, microcontroller and LCD display. The charged battery is also used to switch on the load with the help of load circuit during night. This load circuit is again controlled by the microcontroller.

Different blocks shown in Figure 5 are as under.

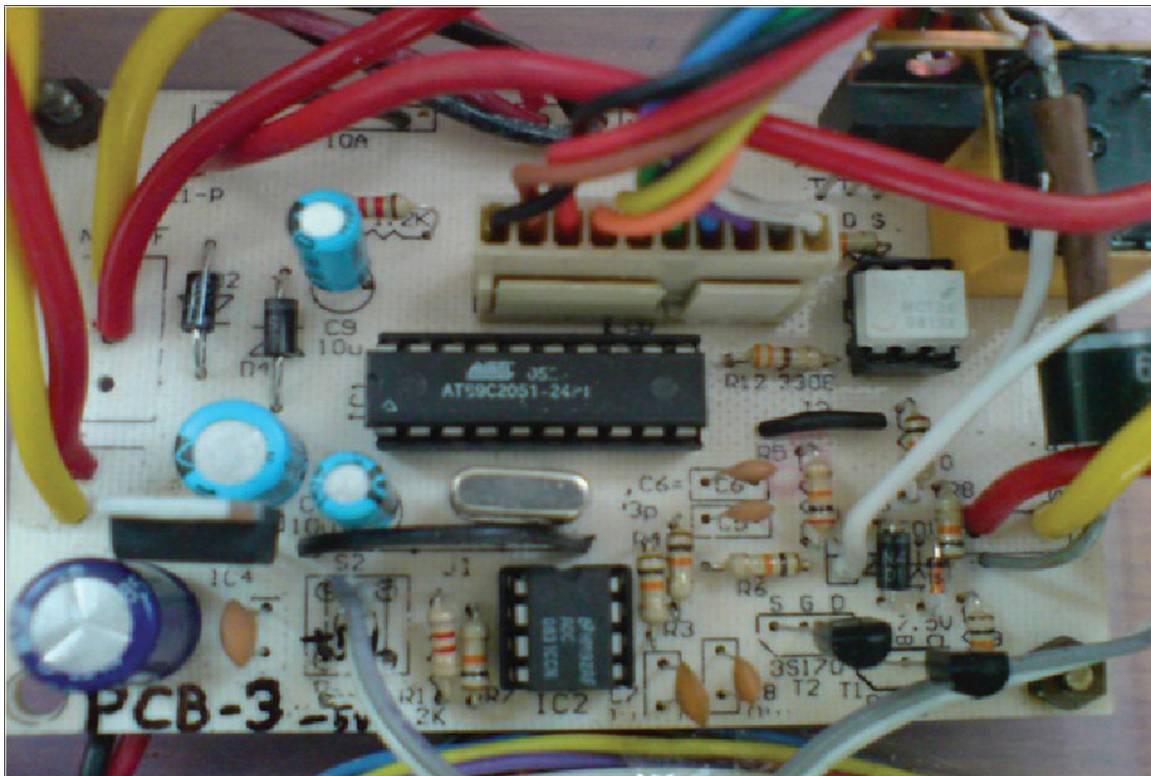

FIG. 5(B) DEVELOPMENT OF SOLAR CONTROLLER CIRCUIT

### 3.4.1 Microcontroller (AT89C2051)

Microcontroller (AT89C2051) is the heart of the circuit. It is a low-voltage, high-performance, 8-bit microcontroller that features 2 kB of Flash, 128 bytes of RAM, 15 input/output (I/O) lines, two 16-bit timers/counters, a five-vector two-level interrupt architecture, a full-duplex serial port, a precision analogue comparator, on-chip oscillator and clock circuitry. A 12 MHz crystal is used for providing the basic clock frequency. All I/O pins are reset to '1' as soon as RST pin goes high. Holding RST pin high for two machine cycles, while the oscillator is running, resets the device. Power-on reset is derived from resistor R1 and capacitor C4. Switch S2 is used for manual reset [3].

### 3.4.2 Serial ADC (ADC0831)

The microcontroller monitors the battery voltage with the help of an analogue-to-digital converter. The ADC0831 is an 8-bit successive approximation analogue-to-digital converter with a serial I/O and very low conversion time of typically 32  $\mu$ s. The differential analogue voltage input allows increase of the common-mode rejection and offsetting of the analogue zero input voltage. In addition, the voltage reference input can be adjusted to allow encoding of any smaller analogue voltage span to the full eight bits of resolution. It is available in an 8-pin PDIP package and can be interfaced to the microcontroller with only three wires [1].

### 3.4.3 LCD Module

The system status and battery voltage are displayed on an LCD based on HD44780 controller. The backlight feature of the LCD makes it readable even in low-light conditions. The LCD is used here in 4-bit mode to save the microcontroller's port pins. Usually, the 8-bit mode of interfacing with a microcontroller requires 11 pins, but in 4-bit mode, the LCD can be interfaced to the microcontroller using only 7 pins [4].

### 3.4.4 Solar Panel

The solar panel used here is meant to charge a 12 V battery and the wattage can range from 10 to 40 watts. The peak unloaded voltage output of the solar panel will be around 19 volts. Higher-wattage panels can be used with some modifications to the controller unit.

### 3.4.5 Rechargeable Battery

The solar energy is converted into electrical energy and stored in a 12 V lead-acid battery. The ampere-hour capacity ranges from 5 Ah to 100 Ah.

### 3.4.6 Panel Circuit

Panel circuit is also called the sensor circuit, as it senses the day–night condition. For example, solar home lighting system, solar lantern or solar streetlight—the load (the light) is switched on at dusk (evening) and switched off at dawn (morning). During daytime, the load is disconnected from the battery and the battery is recharged with current from the solar panel. The microcontroller needs to know the presence of the solar panel voltage to decide whether the load is to be connected to or disconnected from the battery, or whether the battery should be in charging mode or discharging mode. A simple sensor circuit is built using a potential divider formed around resistors, zener diode and transistor for the presence of panel voltage [9].

## 4.0 DEVELOPMENT OF SOFTWARE PROGRAM

Software program for microcontroller-based solar controller circuit is developed in assembly language and assembled using Metalink's ASM51 assembler. Software program can be divided into following parts according to its functioning:

- (a) Main program containing a continuous loop
- (b) Function for checking solar panel voltage
- (c) Function for checking battery voltage

- (d) Function for battery overcharging protection
- (e) Function for pulsed charging in case of battery full charged
- (f) Function for controlling load according to the day–night condition

## 5.0 TESTING AND RESULTS

The circuit is tested in the ‘Solar Energy Lab, MANIT, Bhopal’. The results obtained are very close to expected values. These results shows in Tables 1–4.

TABLE 1							
RESULT FOR RECTIFIER AND SWITCHING CIRCUIT							
Sl. No.	Input supply (Switch position)		Rectifier circuit		Switching circuit (Supply selection relay)		Supply to load
	Mains	Renewable energy	O/P voltage	Indication LED (Red)	Coil	Pole position	
1.	OFF	OFF	0 V	OFF	De-energize	NC	No Supply
2.	ON	OFF	5 V 12 V	ON	Energize	NO	Mains
3.	ON	ON	5 V, 12 V	ON	Energize	NO	Mains
4.	ON	OFF	5 V, 12 V	ON	De-energize	NC	No Supply
5.	ON	ON	5 V, 12 V	ON	De-energize	NC	No Supply
6.	OFF	OF	0 V	OFF	De-energize	NC	No Supply
7.	OFF	ON	0 V	OFF	De-energize	NC	Renewable Energy

TABLE 2					
RESULT FOR MEASUREMENT OF 0.01 kWh OF ENERGY					
Sl. No.	Load (kW)	Time Measured		Energy	
		mm:ss:00	Hour	Measured (kWh)	Displayed (kWh)
1.	0.52 (100 W×4 bulbs+60 W×2 bulbs)	01:09:87	0.0194	$0.52 \times 0.0194 = 0.0100$	0.01
2.		01:11:20	0.0197	$0.52 \times 0.0197 = 0.0102$	0.01
3.		01:10:96	0.0197	$0.52 \times 0.0202 = 0.0102$	0.01
4.		01:09:38	0.0192	$0.52 \times 0.0192 = 0.0100$	0.01
5.		01:10:82	0.0196	$0.52 \times 0.0196 = 0.0102$	0.01

TABLE 3

## RESULT FOR ENERGY CONTROL DURING DAY TIME

Sl. No.	Input Supply (Switch position)		Load (kW)	Time (Measured)		Energy (kWh)		Supply to load
	Mains	Renewable energy		mm:ss:00	hour	Measured	Dis-played	
1.	OFF	OFF	0.521 (100 W × 4 bulbs + 60 W × 2 bulbs)	–	–	–	–	No Supply
2.	ON	OFF		00:02:52	0.0007	$0.52 \times 0.0007$ = 0.0003	0.00	Mains
3.	ON	OFF		01:09:87	0.0194	$0.52 \times 0.0194$	0.01	Mains
4.	ON	OFF		02:18:96	0.0386	$0.52 \times 0.0386$ = 0.0200	0.02	No Supply
5.	ON	ON		02:18:26	0.0386	$0.52 \times 0.0386$ = 0.0200	0.02	Renewable Energy

TABLE 4

## RESULT FOR BATTERY CHARGING

Sl. No.	Time	Solar panel voltage (Volts)	Battery voltage (Volts)
1.	10:45am	17.22	6.34
2.	11:30am	17.24	6.86
3.	12.05pm	17.50	7.42
4.	12.45pm	17.70	7.51
5.	01.30pm	18.41	8.75
6.	01.45pm	18.50	9.50
7.	02.30pm	18.20	10.50
8.	03.30pm	18.01	10.65
9.	04.05pm	17.52	10.72
10.	04.35pm	17.20	11.10
11.	05.15pm	16.05	111.52

All these results have been obtained from the running condition of the implemented hardware. Various Figures 6–11 and 12(A), 12(B), 12(C) related with this implemented hardware are as follows.

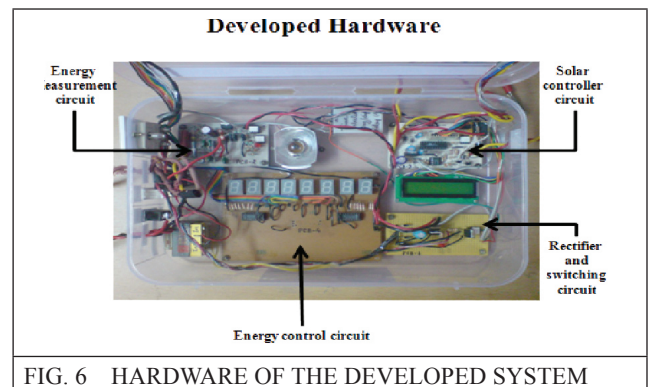



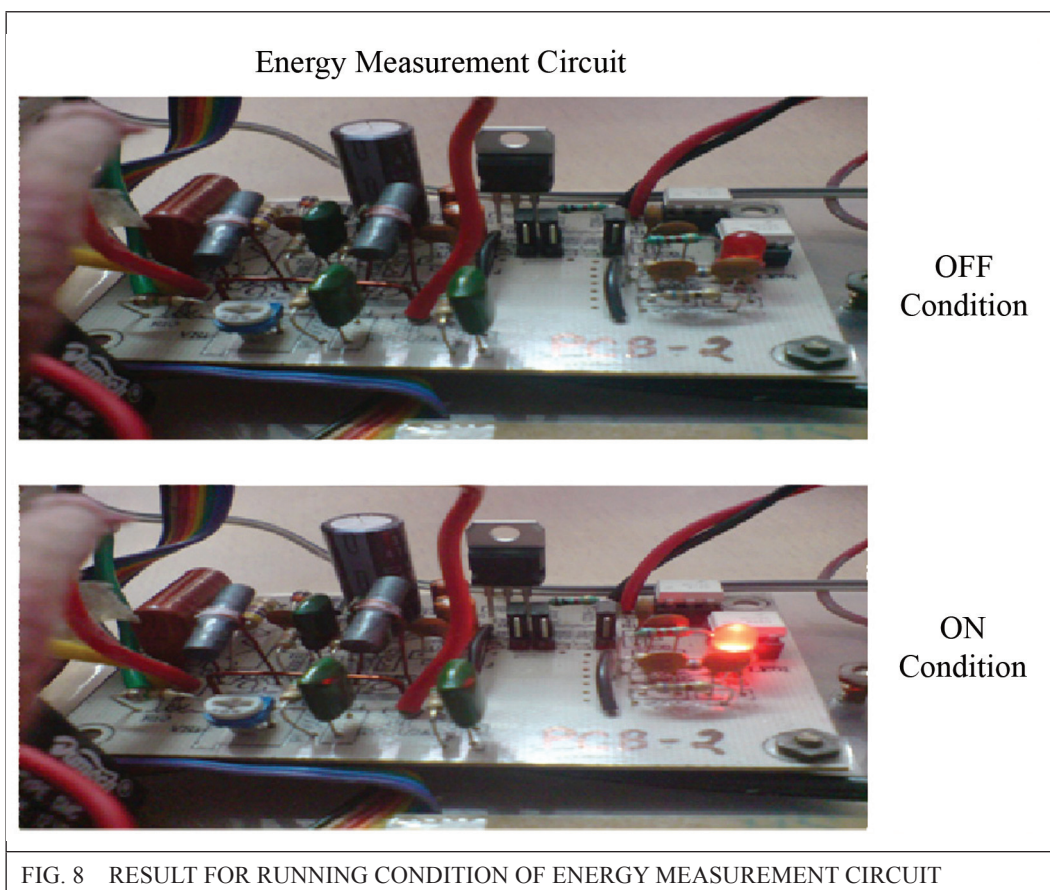
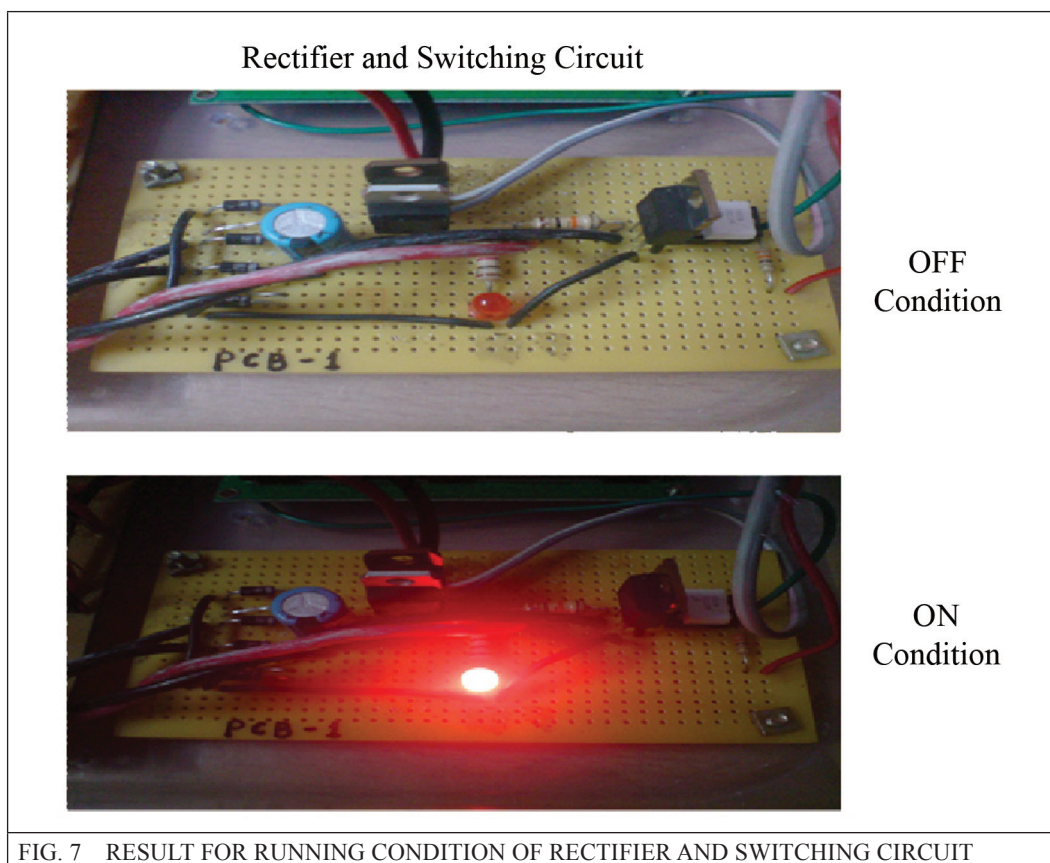

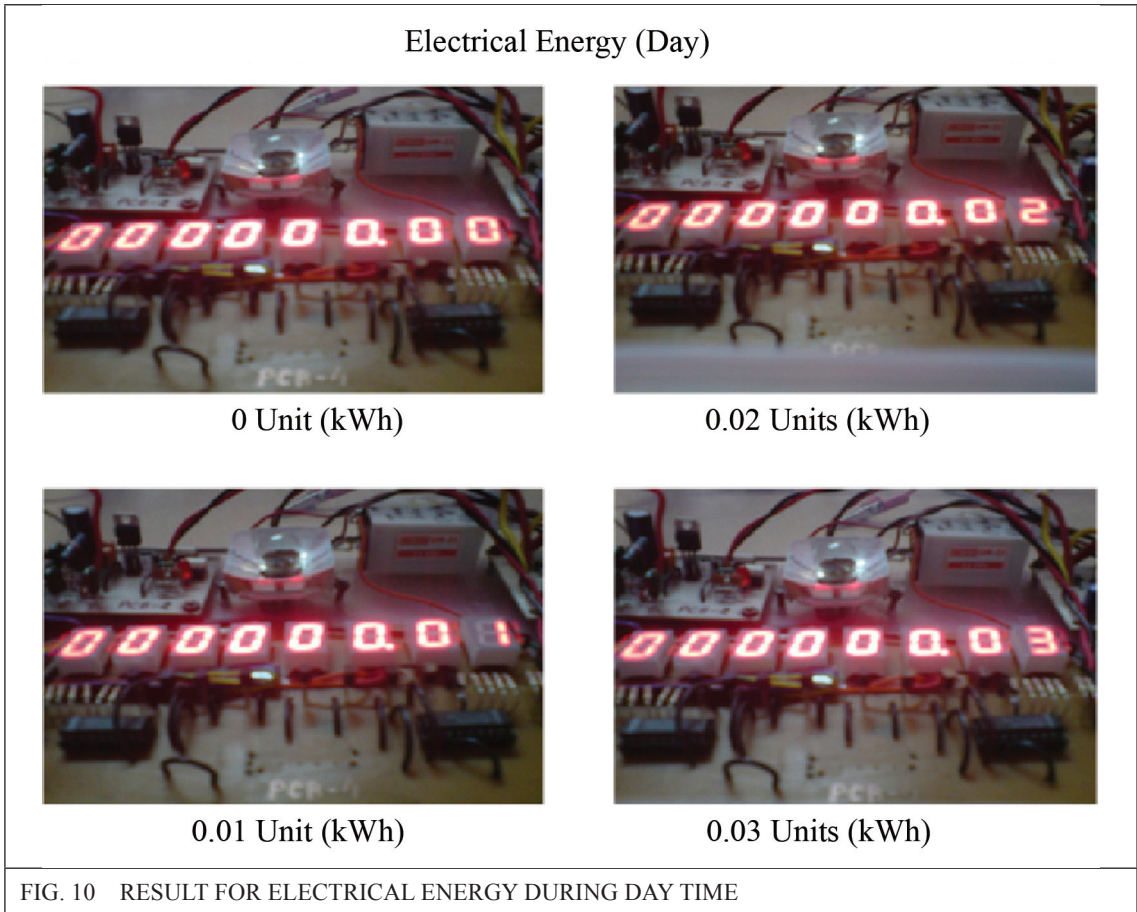
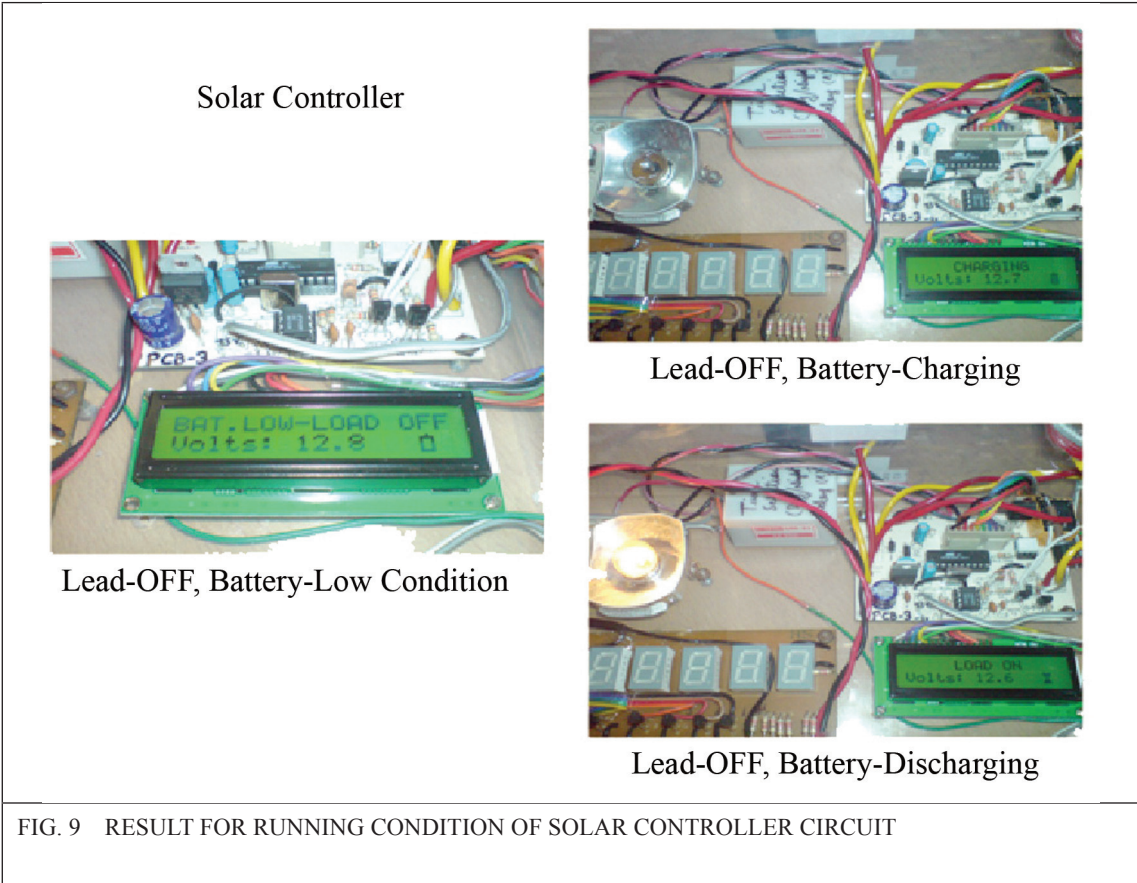



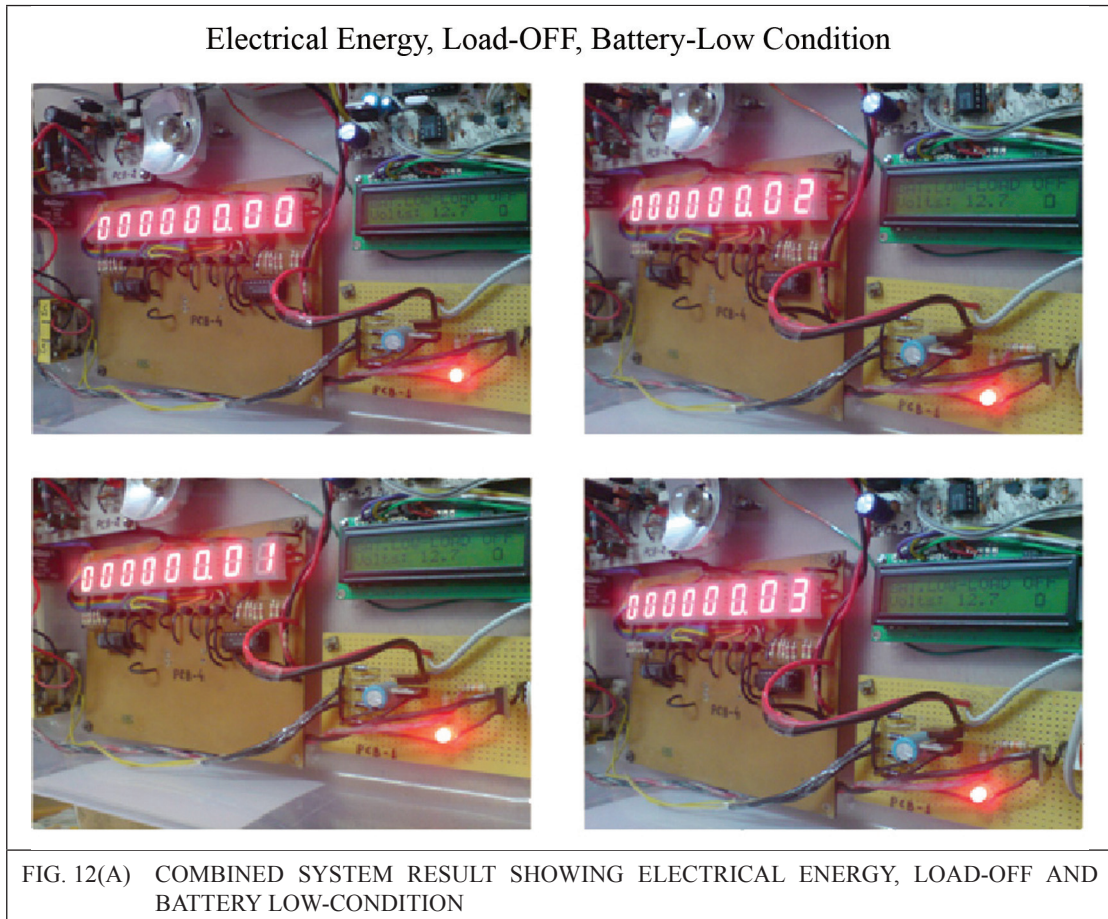
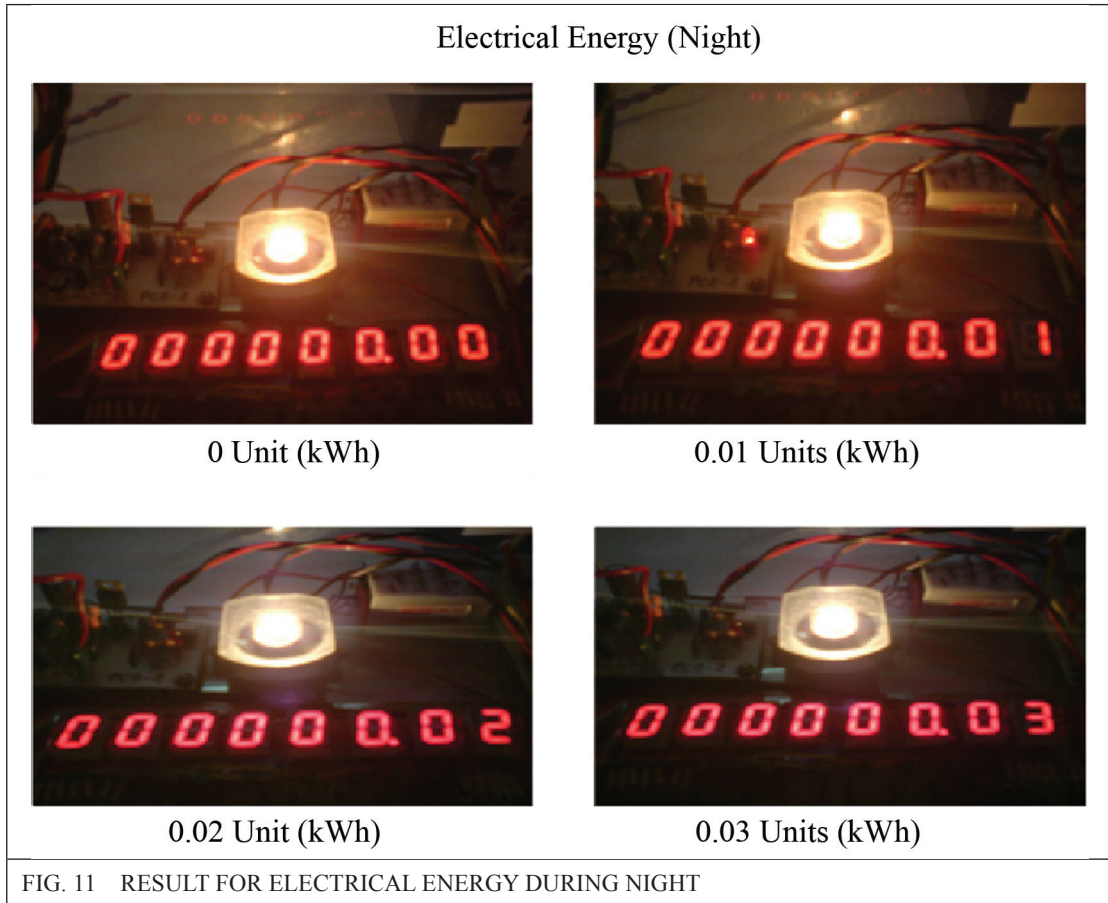

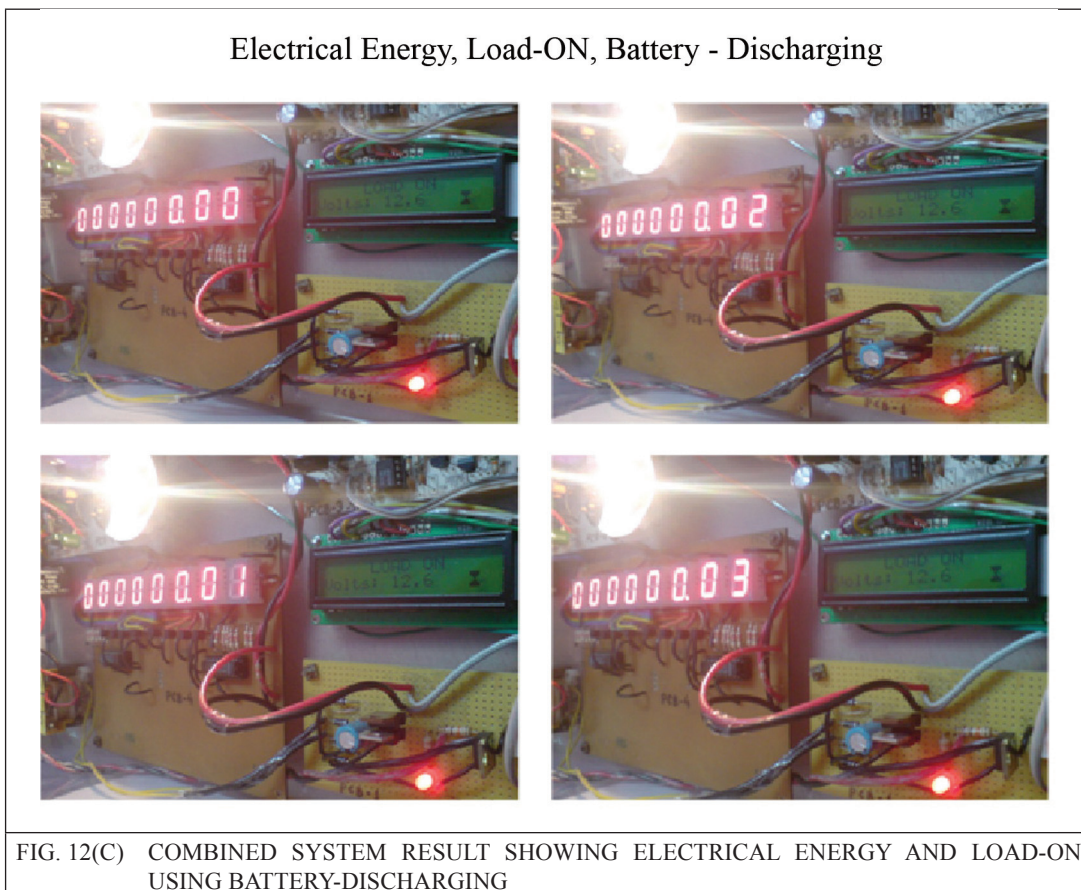
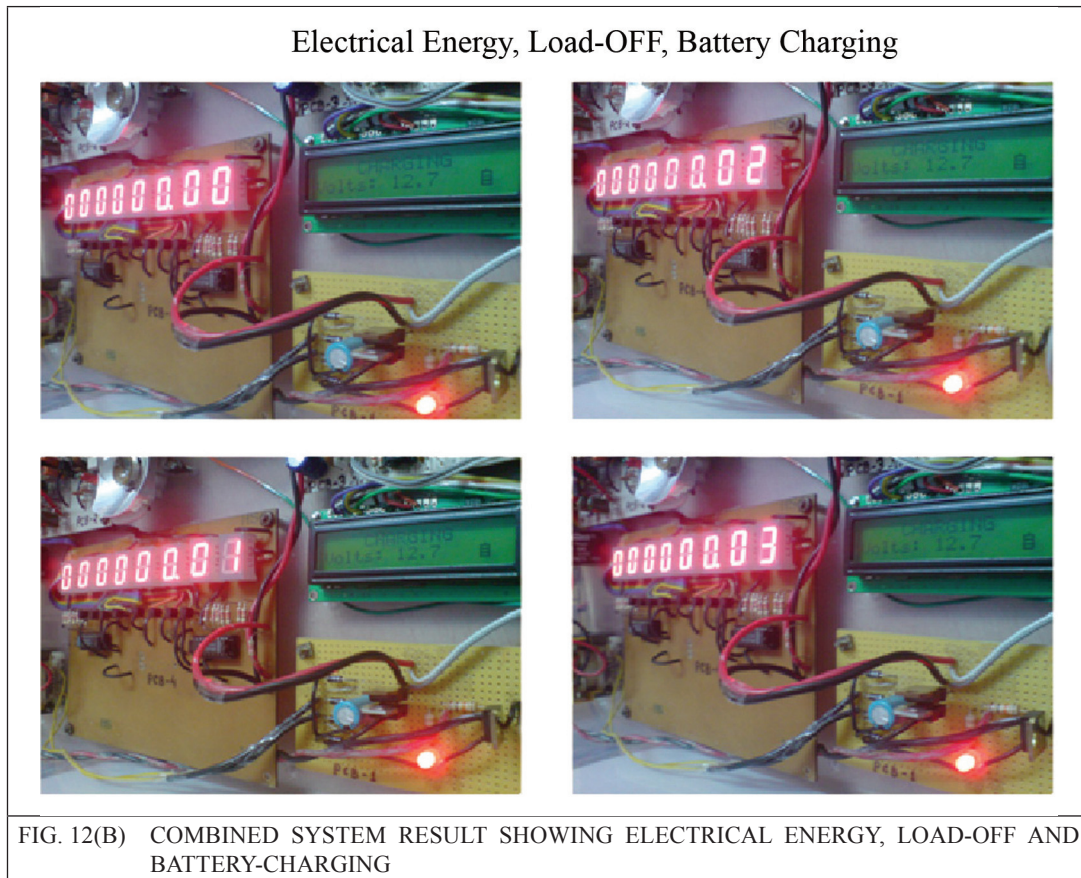



## 6.0 CONCLUSION

The “Measurement and Control of Electrical Energy for the Efficient Energy Management” has an architecture that matches the requirements of electrical energy providers.

One contribution of this system is the ability to control the electrical energy without using expensive technologies like GPRS, mobile communication control, etc., since it uses natural solar energy as a comparator for day and night shifting of energy control. Hence, this project saves the cost. Another contribution is the capacity to measure electrical energy up to 10,00,000 units and to control it up to 2,00,000 units. Such a high amount of electrical energy can be utilized for large number of consumers.

This circuit is capable of replacing conventional analog energy meters which are still being used. It allows the visualization of electrical energy measurement and controlling both and is more accurate, more reliable and cheaper.

The technique presented in this work provides a means for digital measurement of electrical energy over a wide range. Results obtained exhibited linear behavior over the range used. With this circuit, good results under various loading conditions have been obtained.

This circuit is very useful in areas where single-time controlling of electrical energy is required, specially in rural and distant areas because internet, wireless connection or even the human interfering are not required for the controlling of electrical energy, if once the controlling range is selected.

When fixed at electricity pole, it will have its own lighting. Thus, it can be identified at a far distant. Also, the energy measurement and controlling display is 7-segment LED display, so that one can see the amount of electrical energy supplying at a distant and it is a cheaper way, since the LCD cannot be seen at a distant and is more costly.

This whole project setup can work on solar energy; hence it can save the electrical energy.

With the help of this project, the objective of utilizing the renewable energy sources can be achieved.

## REFERENCES

- [1] Ramesh S Gaonkar. *Microprocessor Architecture, Programming and Applications with 8085*, 4th ed., Penram International Publishing (India) Pvt. Ltd.
- [2] Ram B. “Fundamentals of Microprocessor and Microcomputers”, Dhanpat Rai Publications.
- [3] Kenneth J and Ayala. *The 8051 Microcontroller*, 2nd ed., Penram International Publishing (India) Pvt. Ltd.
- [4] Muhammad Ali Mazidi, Janice Gillispie Mazidi, Rolin D and Mckinlay. *The 8051 Microcontroller and Embedded Systems*, 2nd ed., Pearson Education.
- [5] John Markow. “Microcontroller-based energy metering using the AD7755”, *Analog Dialogue*, Vol. 33, No. 1, 1999.
- [6] Vipin Kakkar, “Architecture for efficient energy meter”, *IJCSNS International Journal of Computer Science and Network Security*, Vol. 9, No. 11, November 2009.
- [7] Adalet Abiyev. “A New signal processing based method for reactive power measurements”, *Journal of Computers*, Vol. 4, No. 7, July 2009.
- [8] Catalin Damian, Cristian Zet, Cristian Fosalau, Mihai Cretu. “Real, reactive and apparent power computing using FPGA and PWM intermediary conversion”, *IMEKO International Measurement Confederation*, TC-4, 2008.
- [9] Ding J J, Buckeridge J S. “Design considerations for a sustainable hybrid energy system”, *IPENZ Transactions (The Institution of Professional Engineers New Zealand)*, Vol. 7, No. 1, EMCH, 2000.

