



# Multi-functional UPS for Commercial Use

P. Lakshmana Rao\*, J. Sreedevi and G. N. Chethan

Power Systems Division, Central Power Research Institute, Bengaluru – 560080, Karnataka, India;  
paila.lakshmanarao274@gmail.com, sreedevi@cpri.in, chethangn09@gmail.com

## Abstract

This paper proposes a line-interactive static UPS system with a simple control strategy for the operation of three-leg IGBT based AC/DC converter. Min-Max algorithm based PWM technique is used as switching logic for AC/DC converter. The developed control strategy addresses the applications like reactive power compensation of load, unbalanced currents compensation, active power compensation during peak load time on the grid and Seamless power transfer operation from grid-connected mode to islanding mode. LCL filter is designed to meet the THD limits specified in IEEE Std 519-2014.

**Keywords:** Grid-connected Mode, Islanding Mode, Line-interactive Static UPS, Min-Max Algorithm, Seamless Power Transfer, THD

## 1. Introduction

Uninterruptible Power Supply (UPS) systems provide power to the various types of loads, irrespective of the presence of input power supply. Typically, UPS provides seamless power for essential loads for their successful operation, such as medical equipment of the hospitals, R&D testing lab centres, metal melting industries and critical data handling computers etc.<sup>1</sup>. Nowadays, UPS are not only providing uninterruptible power, also perform some essential functions like low transition time from grid-connected mode to islanding mode and vice versa, load harmonics compensation, unbalanced current compensation and maintaining unity power factor at the point of grid connection<sup>2</sup>. Preferably, UPS should have high efficiency, low THD, less maintenance, less weight and low cost.

UPS systems are classified into three types, those are Rotary, Static and Hybrid systems<sup>3</sup>. A typical Rotary type UPS system contains Motors, Generators and Battery storage system. The main advantage of this type of UPS is reliability but they suffer from problems like less efficiency, high weight, more cost and requiring frequent maintenance. The applications are also mostly restricted to supplying power when grid is failed. Due to the above drawbacks, nowadays static UPS are used. Static UPS systems mainly contains power electronic converters

along with battery energy storage system. These are the most commonly used UPS systems from low power to high power applications, because of operation flexibility, high efficiency, high reliability and low THD. Hybrid UPS systems combine the features of both rotary and static UPS systems but control strategy will be complex and costly. Hybrid UPS systems are preferred in high power applications.

Static UPS systems operate in three configurations namely offline UPS, online UPS, and line-interactive UPS. Both offline UPS and online UPS have a rectifier for charging the battery and an inverter to feed power to the load. Normally offline UPS are used for low power applications up to 600 VA, whereas online UPS are used for high power applications of 5 kVA and above. Out of these two, online UPS have zero transition time from grid-connected mode to islanding mode, because of cascade connection of grid, rectifier, battery bank and inverter in its configuration<sup>4</sup>. Dual-stage conversion leads to low efficiency, low power factor and high THD. These are the major drawbacks of the above two configurations. Line-interactive UPS contains one bi-directional AC/DC converter and battery storage system. The main advantage of line-interactive UPS is having a simple design that results in high reliability and low cost compared to the other two types of UPS systems. Due to its single-stage conversion configuration, offers relatively higher

\*Author for correspondence

efficiency normally greater than 97%. This background study motivated the authors to design control for a line-interactive static UPS system.

Before interfacing with the grid, any AC/DC converter should match its voltage phase angle and frequency with those of the grid. For the grid synchronization, a PLL will be used<sup>5</sup>. After obtaining the grid voltage phase angle from PLL, with the help of abc to dq transformations different control strategies have been developed to address the possible applications of AC/DC converter. For the reactive power compensation, conventional PI controller is used after extracting the dq frame current components to generate the reference currents and uses the hysteresis current control technique to generate the pulse for 3-phase voltage source converter<sup>6</sup>. A control strategy using dq0 transformation is developed for a grid-connected three phase solar inverter system with independent active and reactive power control<sup>7</sup>. A dq theory based predictive current control strategy is used to compensate reactive, harmonic and unbalanced components of load current using a four-leg shunt active filter<sup>8</sup>.

Every UPS will be designed to provide smooth and continuous power to the critical loads at all operating conditions. UPS is developed with a PWM inverter, that switches between voltage controlled and current controlled modes to maintain a continuous, uninterrupted voltage across critical and sensitive loads in the event of a fault on the grid<sup>9</sup>. A LCL filter is often used to interconnect an inverter to the utility grid to filter the harmonics produced by the inverter. A design methodology of a LCL filter for grid-interconnected inverters along with a comprehensive study to mitigate harmonics is described<sup>10</sup>.

All this background study is used to model a line-interactive UPS system in MATLAB Simulink environment. A simple control strategy is implemented to address the applications like reactive power compensation of load, unbalanced currents compensation and active power compensation during peak load time on the grid. Also, this control strategy is tested for both grid-connected and islanding mode of operation of the UPS. Finally, with the same control strategy it is tested and observed that the transition time required for UPS operation from grid-connected mode to islanding mode is less than 5ms, i.e., within  $\frac{1}{4}$  of cycle time, which is practically preferred for Seamless power transfer to the critical loads.

## 2. System Description

The UPS system shown in Figure 1, contains a three-leg bidirectional IGBT based AC/DC converter with a battery energy storage system on the DC side of the converter. DC link voltage is to be maintained at 800V and the converter is connected to Point of Common Coupling (PCC) with the help of a LCL filter. Min-Max algorithm based PWM technique also called Offset addition based PWM technique<sup>11</sup> is used as switching logic for AC/DC converter with 10kHz switching frequency. This method is similar to third harmonic injection PWM technique but no need to generate separate third harmonic signal. By using the three sinusoidal reference signals it will generate third harmonic triangular wave of 25% magnitude of fundamental by using (1).

$$V_{offset} = -\frac{V_{max}+V_{min}}{2} \quad (1)$$

where,  $V_{max}$  and  $V_{min}$  are maximum and minimum values among three sinusoidal reference signals at given point of time. This  $V_{offset}$  will be added to the reference sinusoidal signal of the PWM technique, which brings the amplitude of the reference as low as possible. So that the reference can then be pushed to make it equal to the carrier waveform resulting in the higher output voltage and better DC bus voltage utilization. LCL filter parameters are calculated using the design procedure mentioned in <sup>10</sup> and filter parameters are: L1(Inverter side inductor) = 500 $\mu$ H, L2(PCC side inductor) = 200 $\mu$ H, C = 150 $\mu$ F and small resistance added in series with filter capacitor, so that damping ratio of the LCL filter transfer function will be equal to 0.7. While designing LCL filter, enough care has been taken to satisfy the typical conditions (2) – (3) which avoid the resonance problem that may occurs due to harmonic components.

$$\omega_{res} = \sqrt{\frac{L_1+L_2}{L_1L_2C}} \quad (2)$$

$$10\omega_g < \omega_{res} < 0.7\omega_{sw} \quad (3)$$

where,  $\omega_{res}$  is resonance frequency of LCL filter,  $\omega_g$  is grid frequency and  $\omega_{sw}$  is switching frequency of AC/DC converter. A voltage source of 400V, 50Hz is acting as a grid and a Grid Circuit Breaker (GCB) is used to connect the UPS system with the grid. To test the simulation results in MATLAB, a three phase RL-load of 65kVA is modelled.

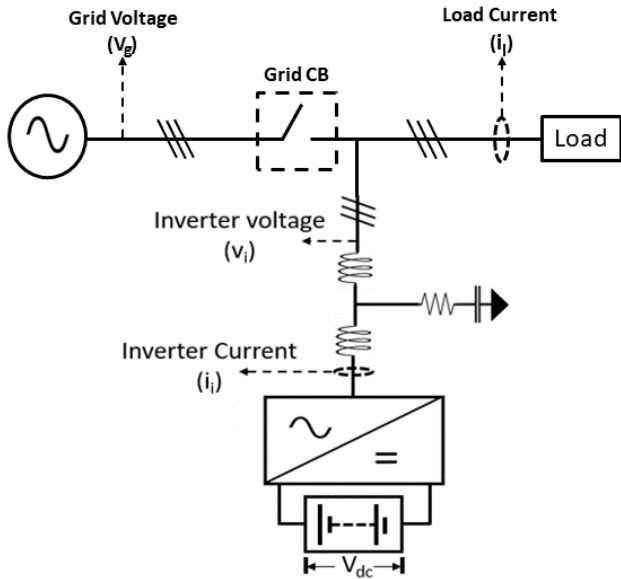

Figure 1. Single line diagram of UPS setup.

### 3. Control Strategy of AC/DC Converter

The setup shown in Figure 1 will operate in two modes. One is islanding mode and other is grid-connected mode. In islanding mode, UPS operates in Voltage Control Mode (VCM). UPS will maintain the user defined voltages ( $v_a^*$ ,  $v_b^*$  and  $v_c^*$ ) at inverter output terminals and battery bank will supply the load power. Whereas in grid-connected mode, UPS will operate in Current Control Mode (CCM) and the reference currents will be obtained from the current control loop.

To operate the AC/DC converter either in VCM or CCM, it is necessary to generate a reference voltage phase angle. A PLL shown in Figure 2 is used to generate a reference voltage phase angle, called as PLL angle ( $\theta$ ) and which will be used to synchronize the load voltage to grid voltage in CCM. In CCM, the output of PI controller i.e., the value of phase shift will vary depending on the value of  $V_q$ . PLL also generate a free running PLL angle when  $V_q = 0$ . This condition appears when the AC/DC converter operate either in VCM or CCM after the synchronization is attained. PI controller is designed to give a fixed phase shift value of  $3^\circ$  when  $V_q = 0$ . It is observed that, with a  $3^\circ$  phase shift value UPS is operating smoothly without any noticeable transients.

#### 3.1 Current Control Mode

The control Strategy of CCM is shown in Figure 3. The reference currents for the AC/DC converter are obtained

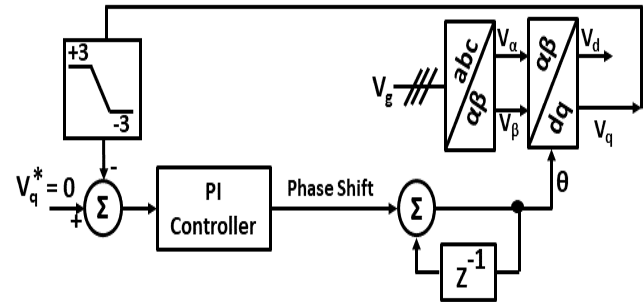

Figure 2. Phase-Locked Loop (PLL).

using the logic shown in Figure 3(I). PLL angle is taken as positive sequence grid angle ( $\theta_+$ ) and the negative sequence grid angle ( $\theta_-$ ) is obtained by complementing the  $\theta_+$ . These two angles are independently used to extract positive and negative sequence components of load currents ( $i_{la}$ ,  $i_{lb}$ ,  $i_{lc}$ ). Clark transformation of abc frame to  $\alpha\beta$  frame and Park transformation of  $\alpha\beta$  frame to dq frame are used to extract  $i_{d+}$ ,  $i_{q+}$ ,  $i_{d-}$  &  $i_{q-}$  from load currents. It is well known that, if the load is unbalanced then the dq components ( $i_{d+}$ ,  $i_{q+}$ ,  $i_{d-}$  and  $i_{q-}$ ) of load current contains a 100Hz oscillating component which is twice the fundamental frequency along with the DC component. Low pass filters are used to extract DC components  $I_{d+}$ ,  $I_{q+}$ ,  $I_{d-}$  and  $I_{q-}$  from  $i_{d+}$ ,  $i_{q+}$ ,  $i_{d-}$  and  $i_{q-}$ . This paper aims for drawing balanced UPF currents from the grid, so the currents  $I_{q+}$ ,  $I_{d-}$  and  $I_{q-}$  required for the load are supplied from the UPS. The term  $\omega^* C^* V_{id}$ , where C is filter capacitance and  $V_{id}$  is direct axis inverter voltage is used to nullify the reactive power sent by capacitance of LCL filter. The component  $I_{d+}$  will be calculated based on the addressed application. Inverse Park and Inverse Clark transformations are used to obtain AC/DC converter reference currents  $i_a^*$ ,  $i_b^*$ ,  $i_c^*$  from  $I_{d+}$ ,  $I_{q+}$ ,  $I_{d-}$  and  $I_{q-}$ .

The control strategy shown in Figure 3(II) generate the reference sine waves for Min-Max PWM technique. Where,  $i_{ia}$ ,  $i_{ib}$  and  $i_{ic}$  are inverter currents.

The design of Proportional-Resonant (PR) controller is done based on <sup>12</sup> and the controller values are tuned in a way that the bandwidth of CCM-control loop is 446Hz as shown in Figure 4. This value is less than one-sixth of the switching frequency, which helps to eliminate the switching noises. This value is five times higher than the fundamental frequency, which helps to ensure a fast dynamic response.  $V_a$ ,  $V_b$  and  $V_c$  are user defined feed forward terms, which are three phase balanced voltages with magnitude equal to grid voltage magnitude.

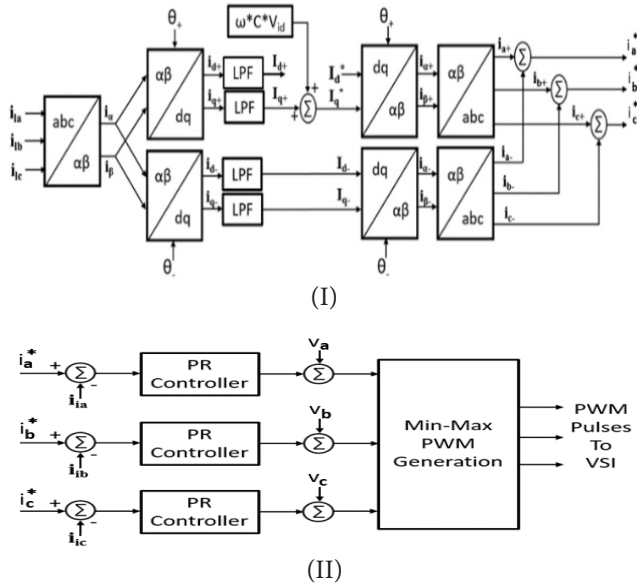

Figure 3. Control strategy of CCM.

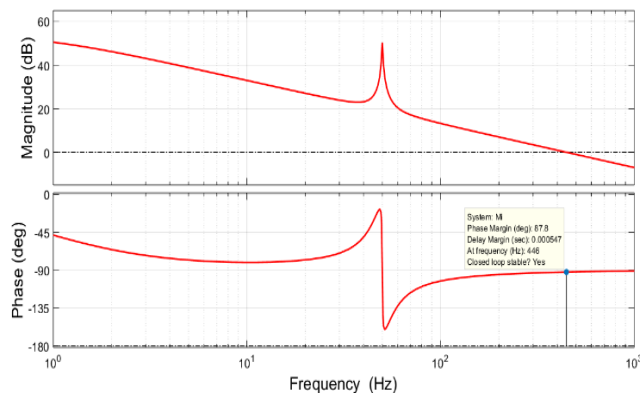

Figure 4. Bode plot of CCM-control loop.

### 3.2 Voltage Control Mode

The control strategy of VCM is shown in Figure 5. Where,  $V_a^*$ ,  $V_b^*$  and  $V_c^*$  are user defined reference voltages given by (4) – (6) with  $V_m = 326$  and  $\theta$  being PLL angle.  $V_{ia}$ ,  $V_{ib}$  and  $V_{ic}$  are inverter voltages.

$$V_a^* = V_a = V_m * \cos(\theta) \tag{4}$$

$$V_b^* = V_b = V_m * \cos(\theta - 120^\circ) \tag{5}$$

$$V_c^* = V_c = V_m * \cos(\theta - 240^\circ) \tag{6}$$

In VCM, the outer PR controller will decide the reference currents and those will be sent as inputs to the inner PR controller.

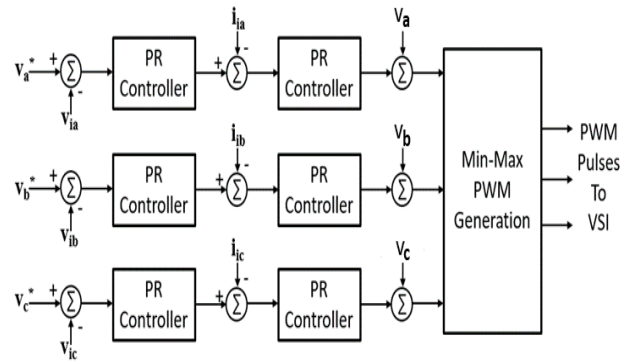

Figure 5. Control strategy of VCM.

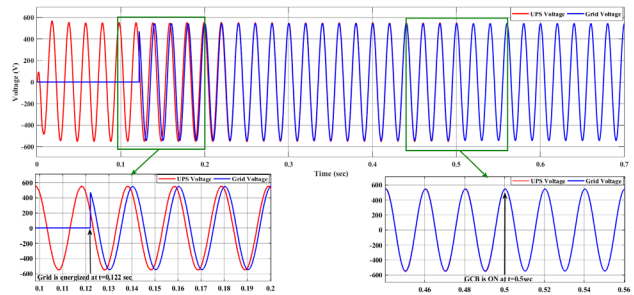

Figure 6. Grid synchronization.

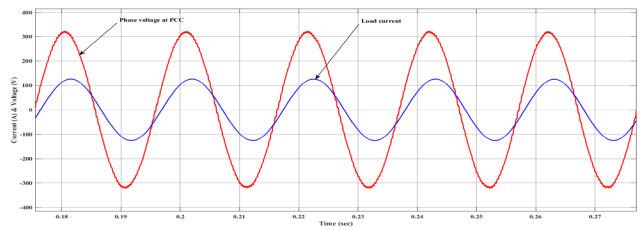

Figure 7. Voltage and current waveforms of the load.

## 4. Results and Discussion

To demonstrate successful operation of the UPS, the addressed applications are reactive power compensation of load, active power compensation during peak load time on the grid, seamless power transfer from VCM to CCM and unbalanced currents compensation.

### 4.1 Grid Synchronization along with Reactive Power Compensation

Grid synchronization is shown in Figure 6. At  $t=0$  sec, UPS is operating in VCM. Therefore, the phase of the voltage at the PCC depends on the free running PLL angle. At  $t=0.122$  sec grid is energized, the value of phase



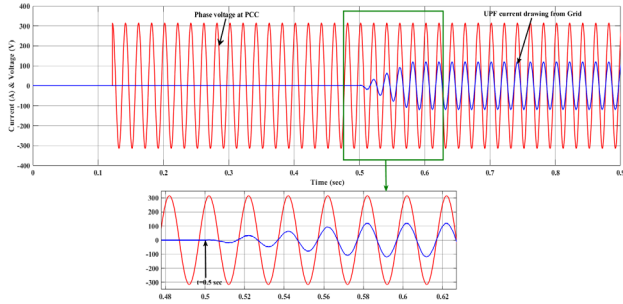

**Figure 8.** Voltage and current waveforms of the grid.

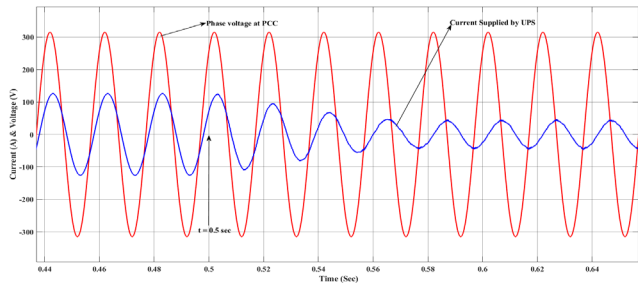

**Figure 9.** Voltage and current waveforms of the UPS.

shift in PLL will be changed to make  $V_q = 0$ . From Figure 6, it is clear that the synchronization process is completed within 5 cycles and GCB is closed at  $t = 0.5$  sec. This indicates that UPS operate in CCM when  $t \geq 0.5$  sec.

Considering a balanced load condition, load voltage and current waveforms are shown in Figure 7.

It is well known that if load is balanced then the dq components ( $i_{d+}$ ,  $i_{q+}$ ,  $i_{d-}$  and  $i_{q-}$ ) of load current contains only DC component, also the values of both  $i_{d-}$  and  $i_{q-}$  are equal to zero. So, these two components will not have any effect in the generation of reference currents for the AC/DC converter. At the start of CCM, AC/DC converter is supplying complete load power. As time  $t > 0.5$  sec, the value of  $I_{d^*}$  will be linearly reduced to zero. Due to this, current drawing from the grid will be increased linearly and it is shown in Figure 8. At this stage, AC/DC converter will supply only reactive power which corresponds to  $I_{q^*}$ <sup>13</sup> and is shown in Figure 9.

The motivation behind the reactive power compensation is to eliminate penalties offered by the utilities when industries failed to maintain their operating PF within the prescribed limits.

### 4.2 Power Sharing at Peak Load time

It is known that utilities encourage industries and farmers to use their electrical appliances during off-peak time. And sometimes they charge higher prices during peak

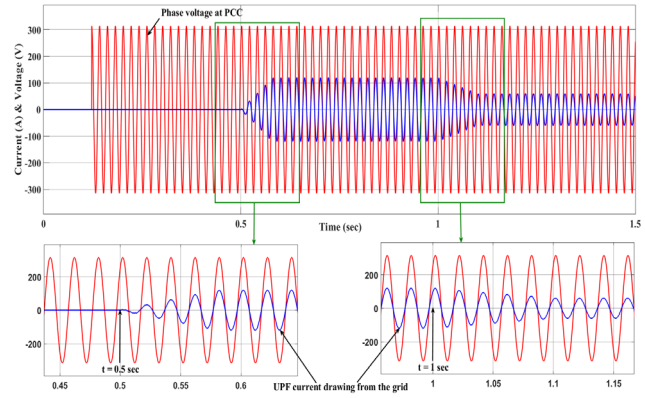

**Figure 10.** Voltage and current waveforms of the grid with 50% active power sharing.

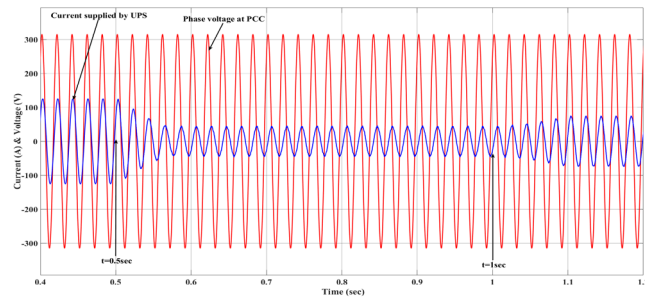

**Figure 11.** Voltage and current waveforms of the inverter with 50% active power sharing.

load. The reason behind this is to maintain loading within the permissible limits.

From  $0 < t < 1$  sec, operating conditions are same as the operating conditions of Section 4.1. So, from  $0.5 < t < 1$  sec, the value of  $I_{d^*}$  is zero. Considering that when  $t > 1.0$  sec, peak load is appearing on the grid. To avoid high electricity tariff rates, during this period UPS will supply 50% of load demand along with reactive power compensation. In order to achieve this, at  $t=1$  sec the value of  $I_{d^*}$  will be increased linearly from zero to half of  $I_{d+}$  value. Due to this, the current drawing from the grid will be linearly reduced to half of its previous value and this is shown in Figure 10. At the same time the current supplied by the UPS increases linearly and this phenomenon is shown in Figure 11.

### 4.3 Seamless Power Transfer

GCB will be opened once grid power is not present, but to reach this status of GCB to the operator at the control room will take some time, called as query time. Practically query time is 59 ms<sup>14</sup>. The operator can't run the system in VCM till the OFF status of GCB is received. Therefore,

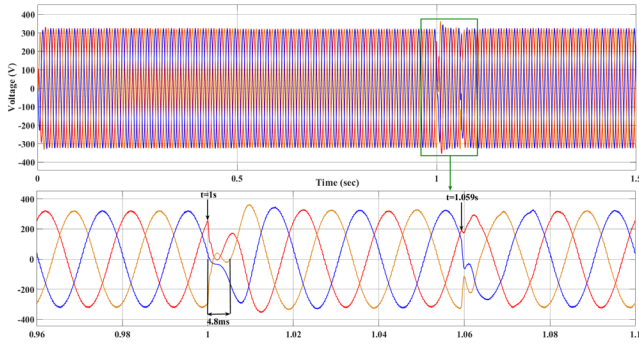

Figure 12. Three phase voltage waveform at PCC.

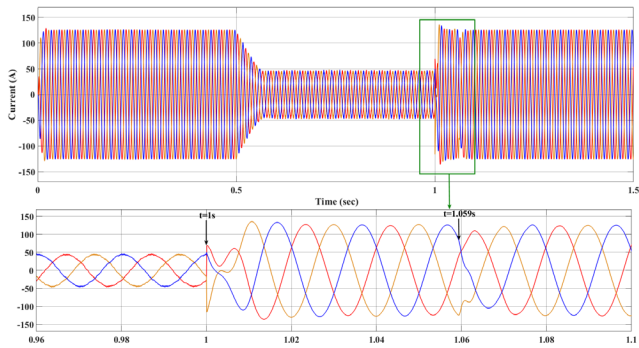

Figure 13. Three phase current supplied by UPS.

during this period UPS will operate in CCM only. It is known that, when UPS operate in CCM then it will supply only part of the load current. Due to this a voltage sag appear at the PCC for a period of 59ms, which may affect the operation of some of the loads like hospitals, R&D testing centres and metal melting plants etc. To avoid this problem a simple solution is given below, with that the voltage at PCC can attain its rated value within 5 ms of time i.e., within ¼ of the cycle and which is practically preferred for seamless power transfer to the critical loads.

From  $0 < t < 1$  sec, operating conditions are same as the operating conditions of Section 4.1. So, from  $0.5 < t < 1$  sec, the value of  $I_d^*$  is zero. At  $t=1$  sec, grid power is off. Due to this voltage at the PCC is drastically falling from its rated value. As soon as UPS detects this condition it will try to send full load power and the value of  $I_d^*$  will increase linearly from zero to  $I_{d+}$ . To achieve the seamless power transfer condition, the value of  $I_d^*$  is increased with a slope of 16A per 1ms. This is achieved due to the designed bandwidth of the CCM control loop, i.e., 446Hz as shown in Figure 4. Three phase voltage waveforms at PCC are shown in Figure 12 and corresponding three phase line currents of the UPS are shown in Figure 13. Therefore, from  $1 < t < 1.059$  sec, UPS operate in CCM delivering

complete load power. At  $t=1.059$  sec, UPS gets the off status of GCB then it will operate in VCM.

### 4.4 Unbalanced Currents Compensation

Due to unbalanced loading, one of the three phases may get overloaded and also negative sequence currents will be injected into the grid, which may seriously affect the performance of the three phase machines connected to the grid. So, it is always preferred to draw balanced UPF currents from the grid.

An un-balanced RL load is modelled with load current waveforms shown in Figure 14. The considered UPS system having a three-leg AC/DC converter, it cannot compensate zero sequence component of load current. Due to this constraint, RL-Load is modelled such that it will draw only positive and negative sequence current components, the remaining operating conditions are the same as Section 4.1. For  $t < 0.5$  sec UPS is operating in VCM and at  $t=0.5$  sec GCB is closed after the grid synchronization. So, from  $t > 0.5$  sec UPS operate in CCM. Due to unbalanced load, the dq components  $i_{d+}$ ,  $i_{q+}$ ,  $i_{d-}$  and  $i_{q-}$  contains a 100Hz oscillating component along with the DC component. Low pass filters are used to extract DC components  $I_{d+}$ ,  $I_{q+}$ ,  $I_{d-}$  and  $I_{q-}$  from  $i_{d+}$ ,  $i_{q+}$ ,  $i_{d-}$  and  $i_{q-}$ . At the start of CCM, i.e., at  $t = 0.5$  sec AC/DC converter is supplying complete load power, which means  $I_{d^*} = I_{d+}$ . At  $t > 0.5$  sec, the value of  $I_{d^*}$  will be linearly reduced to zero. Due to this, current drawing from the grid will be increased linearly and it is shown in Figure 14. After  $I_{d^*}$  become zero, AC/DC converter will supply only currents that corresponds to  $I_{q^*}$ ,  $I_{d-}$  and  $I_{q-}$  and the corresponding three phase currents supplied by UPS are shown in Figure 14. As a result of this action, Load will draw only balanced UPF currents from the grid, as shown in Figure 15.

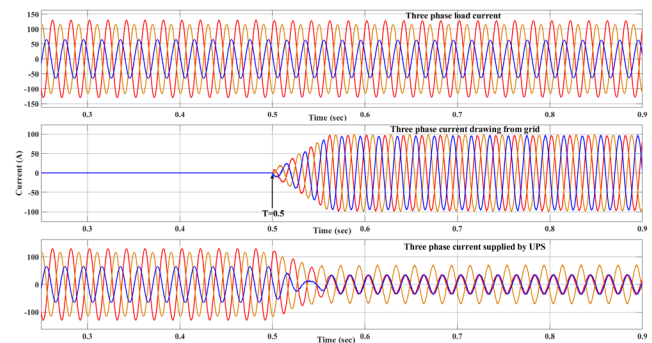
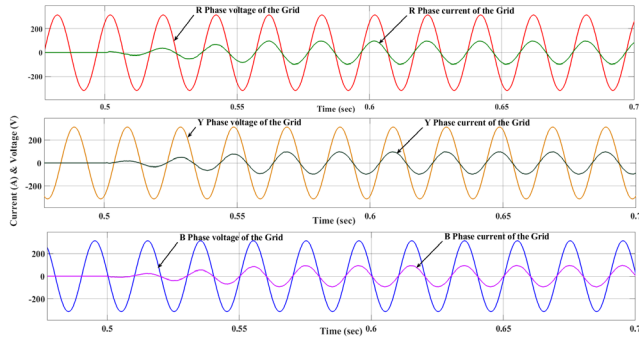

Figure 14. Three phase current waveforms of load, grid and UPS.



**Figure 15.** Balanced three phase UPF currents drawing from grid.

**Table 1.** THD of UPS voltage, current and grid current

Parameters	Voltage at PCC	UPS Current	Grid Current
Sampling Time	1e-06 s	1e-06 s	1e-06 s
Samples Per Cycle	20000	20000	20000
Fundamental peak volts	549.6	125.1	119.6
THD	1.41%	1.14%	1.40%

#### 4.5 THD Analysis

It's a common practice to check the voltage and current distortion limits of any PWM inverter before connecting it to the grid. According to IEEE Std 519-2014, Voltage distortion limit (THD) should be less than 8% and Current distortion limit (TDD) should be less than 5% for the considered rating of UPS. From the simulation, THD of UPS voltage and Current waveforms are 1.41% and 1.14% respectively and that of Grid current is 1.40%. The extract of these values from MATLAB simulation are provided in Table.1, These values are within the specified limits. It is noticed that the rms value of load current and fundamental value of load current are almost same. So, in this case THD will be equal to TDD.

### 5. Conclusion

A three-leg IGBT based AC/DC converter, line-interactive UPS system is modelled in MATLAB Simulink environment. The CCM and VCM control strategy is designed for UPS and successfully simulated. The CCM control is demonstrated for applications like reactive power compensation of load, active power compensation during peak load time on the grid and unbalanced

currents compensation and found that the response is satisfactory. The seamless power transfer operation from CCM to VCM is successfully verified with the voltage at PCC being restored to its rated value within 5ms of time. The THD of the voltage and current waveforms of the UPS and grid current waveform are calculated, and these values are within the specified limits of IEEE Std 519-2014.

### 6. Future Work

The authors are looking forward to implement a microgrid system, which includes proposed UPS system along with a single sensor based solar PV-MPPT inverter system and observe the improvement in transient performance of the developed microgrid system.

### 7. Acknowledgement

The authors would like to acknowledge the support of Dr. Amit Jain and Sri. Sudhakara Reddy S and wish to thank the management of Central Power Research Institute, Bengaluru for permitting to publish this paper.

### 8. References

1. Krishnan R, Srinivasan S. Topologies for uninterruptible power supplies. Proceedings of IEEE International Symposium on Industrial Electronics; 1993. p. 122–7.
2. Yeh C, Manjrekar M. A reconfigurable uninterruptible power supply system for multiple power quality applications. IEEE Transactions on Power Electronics. 2007; 22:1361–72. <https://doi.org/10.1109/TPEL.2007.900486>
3. Bekiarov SB, Emadi A. Uninterruptible power supplies: Classification, operation, dynamics, and control. APEC. Seventeenth Annual IEEE Applied Power Electronics Conference and Exposition. 2002; 1:597–604.
4. Aamir M, Kalwar K, Mekhilef S. Review: Uninterruptible Power Supply (UPS) system. Renewable and Sustainable Energy Reviews. 2016; 58:1395–410. <https://doi.org/10.1016/j.rser.2015.12.335>
5. Chung S. A phase tracking system for three phase utility interface inverters. IEEE Transactions on Power Electronics. 2000; 15(3):431–8. <https://doi.org/10.1109/63.844502>
6. Rastogi M, Bhat AH. Reactive power compensation using static synchronous compensator (STATCOM) with conventional control connected with 33kV grid. 2015 2nd International Conference on Recent Advances in Engineering and Computational Sciences (RAECS); 2015.

- p. 1–5. <https://doi.org/10.1109/RAECS.2015.7453392>. PMID:26117194
7. Schonardie MF, Martins DC. Three-phase grid-connected photovoltaic system with active and reactive power control using dq0 transformation. 2008 IEEE Power Electronics Specialists Conference; 2008. p. 1202–7. <https://doi.org/10.1109/PESC.2008.4592093>
  8. Dheepanchakkravarthy A, Muthuvel P, Selvan MP, Moorthi S, Babu BC. Predictive current control of FL-shunt active filter for dynamic and heterogeneous load compensation. *Electrical Engineering*. 2021. <https://doi.org/10.1007/s00202-021-01224-6>
  9. Tirumala R, Mohan N, Henze C. Seamless transfer of grid-connected PWM inverters between utility-interactive and stand-alone modes. *Proceedings of IEEE Applied Power Electronics Conference and Exposition*; 2002. p. 1081–6.
  10. Reznik A, Simões MG, Al-Durra A, Muyeen SM. LCL filter design and performance analysis for grid-interconnected systems. *IEEE Transactions on Industry Applications*. 2014; 50(2):1225–32. <https://doi.org/10.1109/TIA.2013.2274612>
  11. Khan AM, Iqbal A. Comparative study between existing and proposed pwm techniques for three phase voltage source inverter. *IEEE India International Conference on Power Electronics (IEEE IICPE-2010)*; 2011.
  12. Parvez M, Elias MFM, Rahim NA. Performance analysis of PR current controller for single-phase inverters. *4th IET Clean Energy and Technology Conference (CEAT 2016)*; 2016. p. 1–8. <https://doi.org/10.1049/cp.2016.1311>
  13. Akbarali MS, Subramaniam SK, Natarajan K. Real and reactive power control of SEIG systems for supplying isolated DC loads. *Journal of The Institution of Engineers (India): Series B*. 2018 Dec; 99(6):587–95. <https://doi.org/10.1007/s40031-018-0350-8>
  14. Available from: <https://search.abb.com/library/Download.aspx?DocumentID=1SDC007108G0202&Language-Code=en&DocumentPartId=&Action=Launc>